



The Unimog.

U 400/U 500.



Mercedes-Benz
Trucks you can trust



MBMAN



The Unimog concept.

Getting through where others give up.

Where even all-wheel drive trucks reach their limits and tractors can't go any further, a totally different kind of work and tractor vehicle has to take over: the Unimog. It embodies the meaning of versatility and viability on four wheels. The Mercedes-Benz Unimog is a vehicle in a league of its own. It provides solutions which no other vehicle worldwide can offer. The Unimog is much more versatile than any other with its attachment and mounting areas at the front, middle and rear. It is also much more at home on off-road terrain than any other vehicle, and can drive at fast speeds on roads as a transporter. The Unimog is an uncompromising professional for uncompromising professionals. Superior in every situation and over any terrain.

Contents.

Model Range U 400/U 500.	4 - 5
Chassis Expertise.	6 - 9
Vehicle Drive.	10 - 13
System and Implement-Carrying Expertise.	14 - 17
Mechanical Drives for Implements.	18 - 19
Hydraulic Drives for Implements.	20 - 23
Easy to Operate and Ergonomic.	24 - 25
Panoramic Cab.	26 - 27
Economic Efficiency and the Environment.	28 - 29
Worldwide Service and Financial Services.	30 - 31





The Model Range U 400/U 500. Unique Versatility.

Whether mowing, clearing or cutting snow, gritting, cleaning, sweeping or transporting – the Unimog U 400/U 500 is extremely suitable for all kinds of jobs: It can be equipped more individually than any other mass-produced vehicle. Four attachment and mounting areas provide almost endless possibilities. It is more versatile and reliable off-road than any all-wheel drive truck, with its top speed of up to 90 km/h it is faster than any tractor – and its low fuel consumption is also more than convincing. As a professional implement carrier over 11.99 t max. weight, the Unimog U 400/U 500 gives unrivalled top performances. Designed especially for professionals who appreciate top performance and economic efficiency in a single vehicle for year-round use.

Off-road capabilities.

Where others get wheelspin, the Unimog really gets going. With portal axles, permanent all-wheel drive, differential locks, extreme axle articulation and reduction gears for off-road the U 400/U 500 can do everything you expect of a true Unimog in difficult terrain. It accepts every challenge – also off the beaten track.

MBMANUA





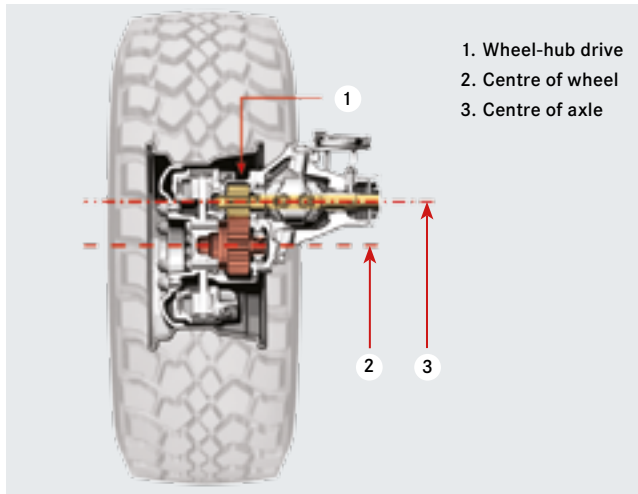

Portal axles provide outstanding ground clearance combined with large volume tyres.

Portal axles with disc brakes cope with any kind of terrain. Portal axles give the Unimog U 400/U 500 its outstanding ground clearance for difficult off-road conditions and – thanks to its high maximum axle load – even with attached or mounted implements. The axle steering guide with integrated anti-roll bars ensures stable handling, has only slight roll and pitch and excellent directional stability during spring extension and compression.

- High ground clearance with low vehicle centre of gravity
- Axle tube and differential positioned over the wheel centre are much smaller than in a truck
- Good cornering characteristics even with full load

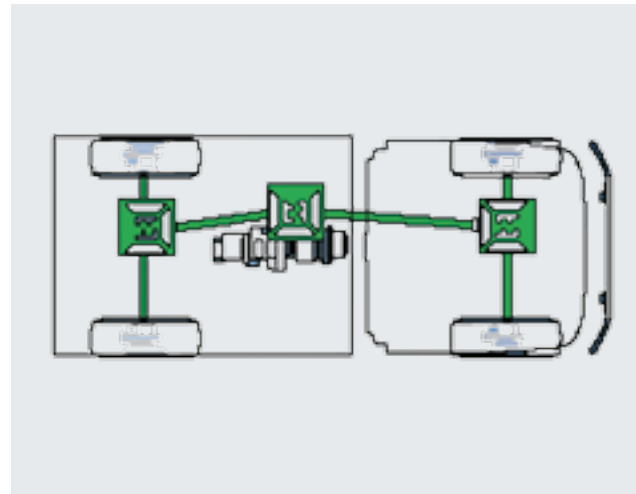

Excellent traction. Permanent all-wheel drive with engageable differential locks on both axles.

Permanent all-wheel drive. Hauling power. The standard permanent mechanical all-wheel drive gives top traction and directional stability, for example in winter conditions. When maximum traction is required in treacherous off-road terrain, the inter-axle differential and the differentials on each axle can be locked while on the move by means of a rotary switch without interrupting tractive power.

- Low wear and tear
- Excellent handling stability and safety during winter operations
- 100% locking effect at both axles for non-slip power transmission to all four wheels

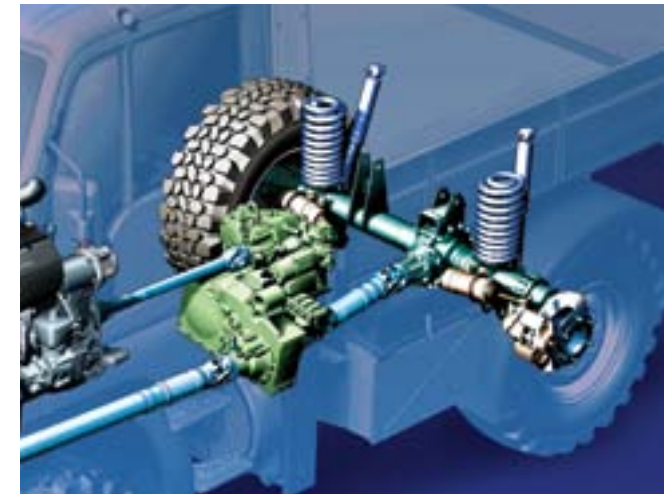

Coil springs and a high degree of axle articulation keep all wheels firmly on the ground.

Coil springs. Always in contact with the ground. Progressively extended coil springs with telescopic shock absorbers give the vehicle the most comfortable suspension irrespective of load. All four wheels remain in contact with the ground even when off-road due to long shock courses and great axle articulation.

- Very comfortable ride
- Minimal self-steering characteristics
- Optimum suspension adjustment to all vehicle loads

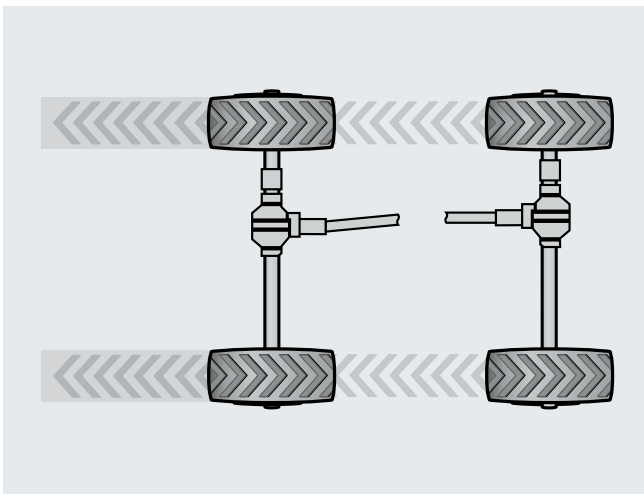

Single tyres increase handling stability and traction and keep rolling resistance low.

Single tyres. Improved traction off-road. Unlike conventional all-wheel drive trucks, the rear axle of the Unimog is fitted with single and not twin tyres. This gives better traction, thanks to lower rolling resistance due to the fact that the rear wheels follow the compacted tracks of the front wheels. The wide range of tyre sizes and types means that the Unimog can be fitted individually for very varying jobs.

- Wide range of different tyres – from small, high-pressure truck tyres to large-volume, low-pressure agricultural tyres
- Depending on tyre size, chains can be fitted easily and fast for winter service or difficult terrain
- Less slippage, saves fuel and spares ground surface from damage



With Tirecontrol, the tyre pressure can be regulated while on the move.



Tirecontrol (tyre pressure regulation system). Always driving with the correct tyre pressure. A further plus when driving over challenging or soft terrain: Tirecontrol, the optional system for adjusting tyre pressures quickly and flexibly to suit changing surface conditions while on the move. The air pressure is lowered at the touch of a button to increase the tyre contact area, thus preventing it from sinking into soft ground and increasing traction.

- Excellent traction, effective self-cleaning and less noticeable tracks off-road
- Flexible adaptation of inner tyre pressure to on-road and off-road conditions while in motion
- Tyre damage due to too low or too high air pressure can be avoided
- Avoids damage to farmland by using lower tyre pressure



Even greater safety, thanks to anti-lock braking system (ABS).

ABS and ALB. More intelligent braking. The standard anti-lock braking system guarantees increased safety and driving stability. It can also be switched over when driving off-road or the differential locks opened automatically. The automatic load-sensitive braking system (ALB) makes sure the Unimog brakes steadily according to its load, even on long downhill stretches.

- More safety through excellent driving stability and steering ability
- ABS control for each individual wheel
- ALB – braking force control depending on the load

Vehicle Drive.

With the Mercedes-Benz Unimog U 400/U 500 you really get going. And have the right amount of power for the job at hand. You can manage even heavy loads or very low speeds without letting the clutch slip. That means less wear and tear – also on your nerves.

MBMANUALS.COM





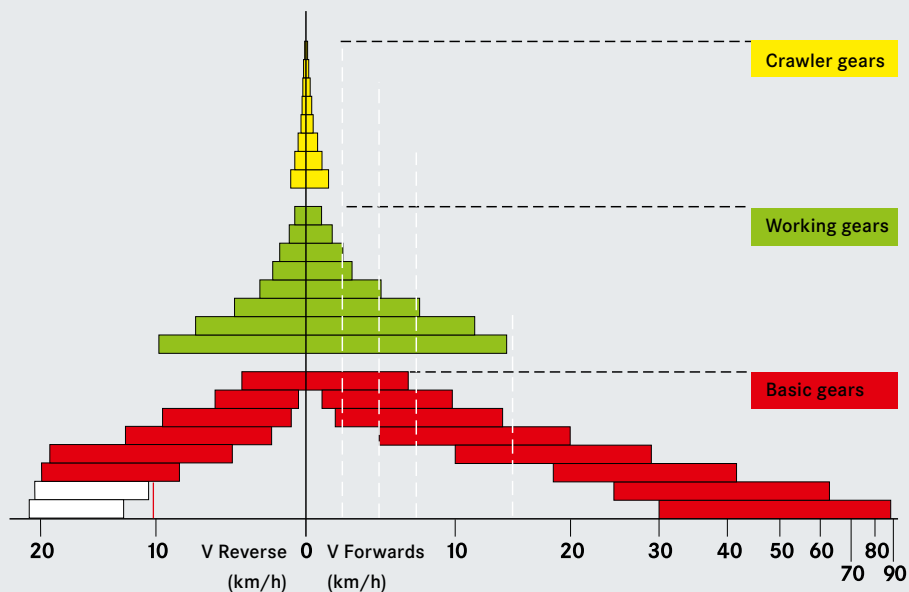

With a total of 24 forward and 22 or 24 reverse gears, the Unimog U 400/U 500 provides optimal working and driving speeds for every job.

Transmission. As versatile as you need it to be. The full-synchromesh electro-pneumatic transmission (Telligent) featuring eight forward and either six or eight reverse gears is renowned for its extremely smooth running, long life span and great efficiency, and it is perfectly designed to deal with a wide variety of jobs. The synchromesh quick reversing system EQR (Electronic Quick Reverse) makes it easy to change directions quickly, for instance when clearing snow in car parks or rocking free off-road.

- The right gear for maximum efficiency and economy, no matter which job needs doing
- Fast, directional changes for clearing snow or manoeuvring

Telligent Gearshift. Shifts in a flash. Tap the gearshift lightly to front or rear – and the shift control will instantly calculate the torque and, depending on the engine speed, the appropriate gear to engage, which is then shown on the display. If you agree, you only have to press the clutch. Otherwise, simply select the gear you want manually.

- Easy on the engine, clutch and transmission
- When shifting gears, the right hand is free – e.g. to operate implements
- Relaxed, concentrated driving



Rocker switch in the centre console for the basic, working and crawler gears.

Working and crawler gears. Full power at every speed.

The basic gears can be supplemented easily depending on the job. The working gears (8/8) can take a full load, are appropriate additions to the speed sector and increase traction. With the crawler gears (8/8), full PTO power can be reached, even at low speeds.

- A total of 24 forward and 22 or 24 reverse gears for performance individually adapted to the job
- Electro-pneumatic operation with a rocker switch for basic, working and crawler gears

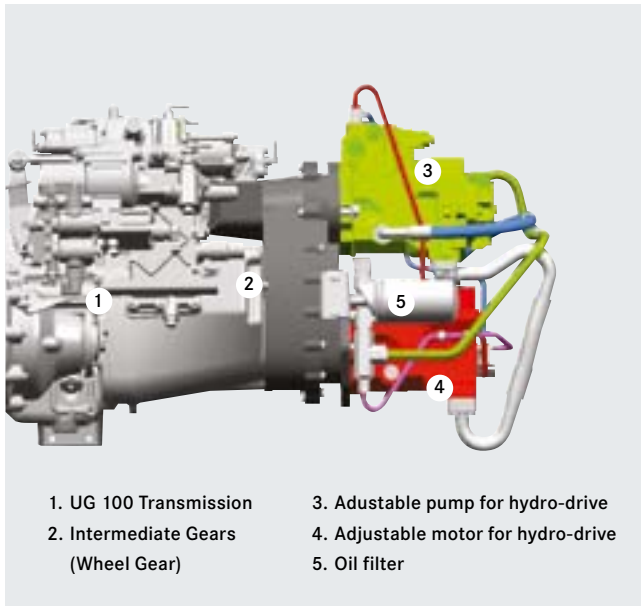

Easy adjustment of the working speed with the hydrostatic transmission drive.

Converter and clutch Unit. Also a match for extra-heavy loads. The hydrodynamic torque converter enables the starting torque to be increased to as much as double the engine torque – exactly what is needed for pulling heavy loads. Once a certain rpm ratio is reached, the torque converter lockup clutch engages a direct connection between engine and transmission. Full adhesion is thus established.

- Increased starting torque for heavy loads
- No jolting when pulling away, lower clutch wear
- Fewer gear changes (vehicle can pull off one to two gears higher)



Hydrostatic drive can be regulated individually using manual shift.

Hydrostatic drive. Constant rpm with varying working speeds. The hydrostatic drive is yet another vital labour-saving feature which allows the working speed to be adjusted easily while maintaining constant rpm for engine and power take-off. The accelerator pedal can be used for accelerating and decelerating the vehicle sensitively, smoothly and jolt-free between 0–25 km/h. Tipping the rocker switch reverses the direction of travel. Swiftly and safely.

- Efficiency in mowing mode due to optimal driving speed
- Reliable operation also on steep slopes and while towing trailers
- Foot-operated (for simultaneous implement control) or manual control
- Three different selectable driving modes depending on driving situation



Switch between manual and automatic modes at the touch of a button.

AutomaticShift. Gearshifting as you like. Drive and work without the clutch, just like automatic transmission; AutomaticShift is a true blessing whenever working and driving requires frequent gear shifting. More attention can be paid to both job and traffic. Plus, you can switch back to manual mode whenever you want at the touch of a button. M denotes manual and A automatic. There is no need to use the clutch in either mode. What makes this shifting system unique is that even in automatic mode drivers are still able to change gears manually using the shift lever.

- Less wear on the clutch
- Uses less fuel
- Choice between automatic gearshifting (e.g. for driving in traffic) or manual gearshifting (e.g. when operating implements or driving off-road)

System and Implement- Carrying Expertise.

Gets to work on all kinds of jobs - the Unimog U 400/U 500 has a uniquely versatile platform for various implement combinations and a multitude of purposes. That is what makes it so economical for year-round work. Thanks to many decades of cooperation between Mercedes-Benz and implement/body manufacturers, expert knowledge and 60 years experience in development can be combined to produce your Unimog. Advantages you can feel metre after metre.





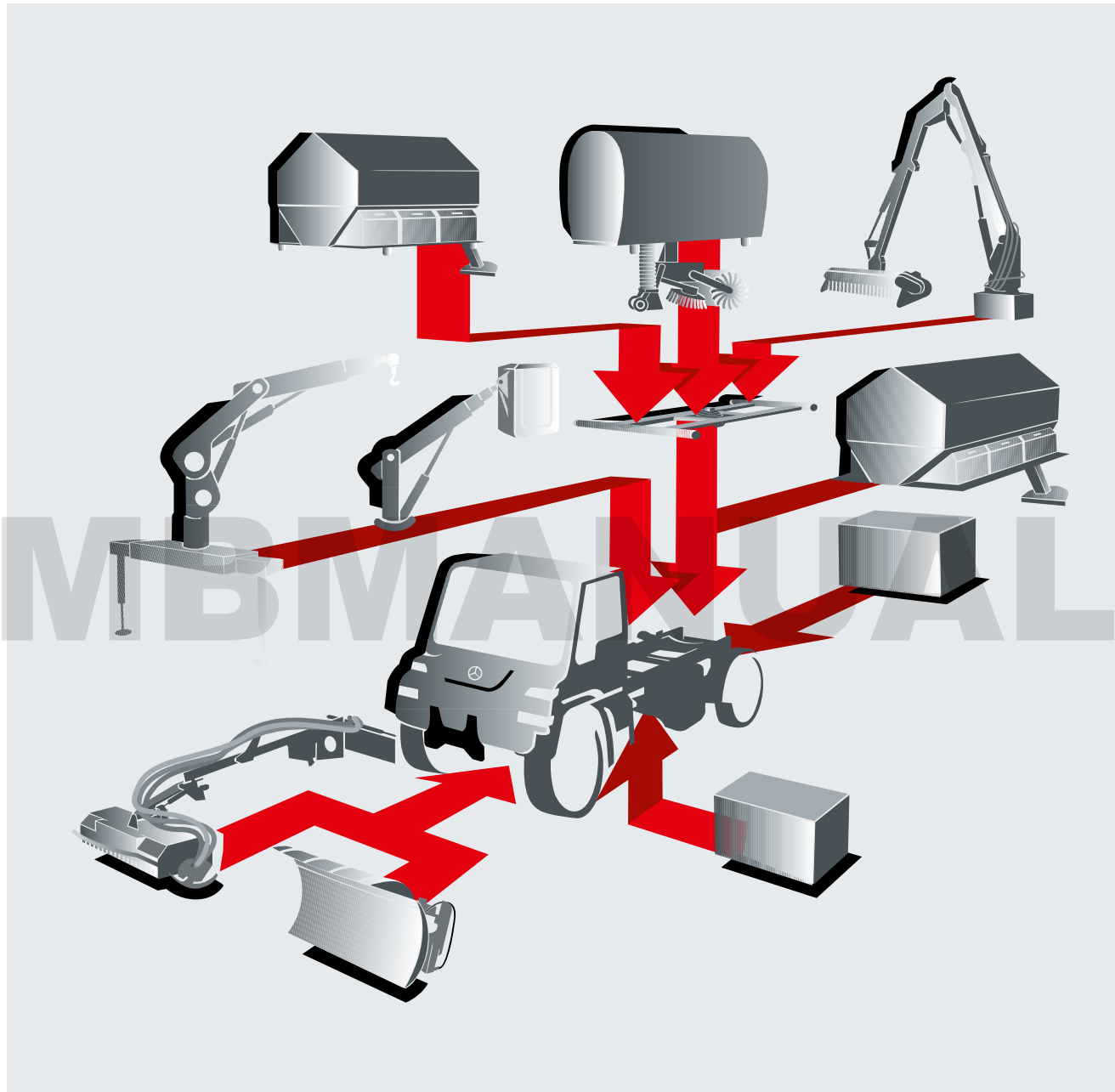

Three attachment areas. More efficient operation.

Three attachment areas – on the front mounting plate, between the axles and at the rear – allow various implements to be attached. Simultaneous multitasking with the Unimog is therefore simple – fast, easy and cost-effective.

- **First:** the front attachment area with standardised front mounting plate (e.g. for verge cutters, snowploughs, snow cutters, winches and front-mounted sweepers)
- **Second:** the inter-axle attachment area (e.g. for road sweepers or graders)
- **Third:** the rear attachment area (e.g. for smaller, quick-change rear-mounted cranes/power lifts or sewer cleaners)

One mounting area, three options. Always the right implement solution. With or without the drop-side body, the mounting area with its three options makes the Unimog U 400/U 500 extremely versatile. If necessary, the tipper body can simply be taken off the tipping cylinder with the quick-release catch to allow much higher payloads.

- **First:** implements can be installed on the body
- **Second:** implement systems can be attached directly to the ball-type fastening points on the body sub-frame (extra payload through removing body)
- **Third:** permanent bodies or seasonally changing implements can be mounted directly onto the straight frame side member

Up to four attachment/mounting areas: no implement carrier is more versatile than the Unimog.



A robust, continuous ladder-type frame with integrated fastening points make direct implement mounting simple and inexpensive.

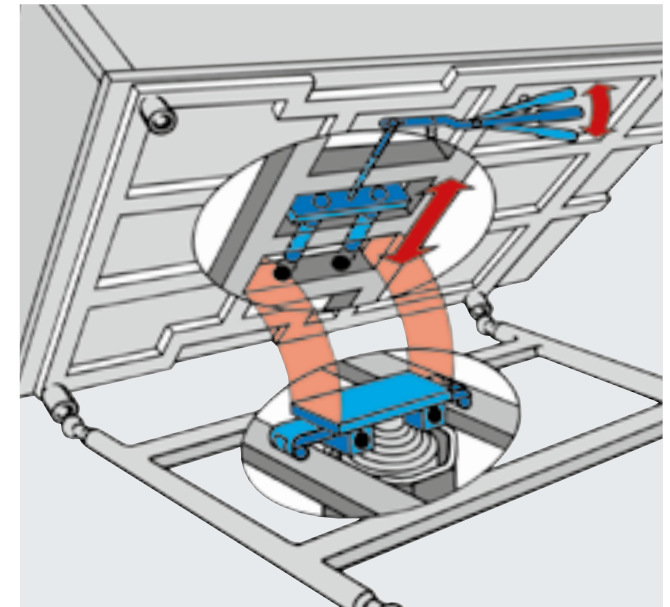

The tipping cylinder can be easily removed from the tipper body.

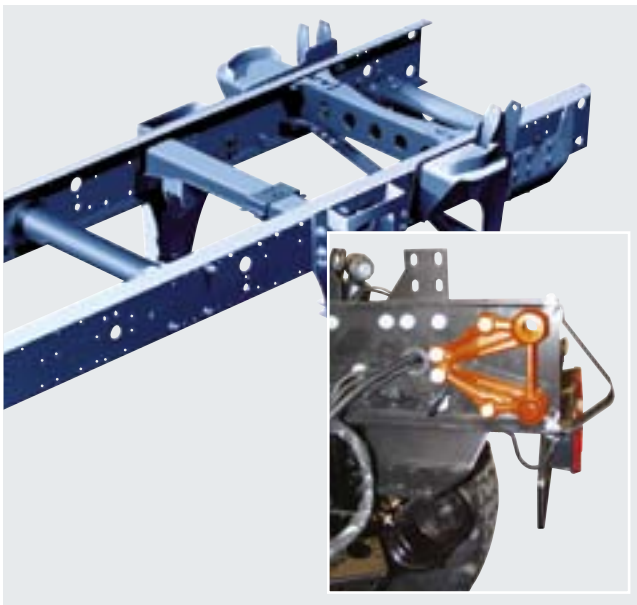

Rear mounting brackets for simple implement mounting.

Frame design. Safe, cost-effective, robust. The basis for the cost-effective all-year-round operation of the Unimog U400/U500 as a professional off-roader implement carrier is its continuous, straight ladder-type frame. It allows implements to be attached directly and easily. High bending and torsional resistance give maximum stability. Integrated mounting positions and hole patterns make attaching and mounting easier and provide additional safety during extreme operations.

- Simple direct mounting on frame side members
- Designed for maximum thrust and traction while ensuring good handling with and without implements
- Designed for attaching several implements at the same time

Defined attachment areas. For fast and easy fitting.

At every Unimog mounting area all necessary attachment points are pre-installed and compatible with existing instruments.

- Developed ex works and coordinated with implement and body manufacturers
- Simple assembly
- Defined load mounting points
- Safeguarded against overload

Mechanical Implement Drives.

The robust Unimog U 400/U 500 can run implements requiring a great deal of power off its mechanical front power take-off which can provide a continuous output of up to 150 kW. The drive element of the rear PTO also provides a continuous output of 120 kW.

MBMANUALS.PK





Front PTO for implements with a high output. Retrofit: rear PTO in standard configuration.

Front power take-off. An extra plus for implements.

Implements with high power consumption are best run directly by the powerful engine-driven front power take-off. With its power output of 150 kW, this standard oil-cooled PTO has a 44.4 mm (1 3/4") spline profile for high torque transmission and is extremely efficient. The digital rpm display and electronic engine control allows the PTO speed to be adjusted sensitively between 420 and 1,000 rpm with extreme precision and infinitely variable.

- **Direct mechanical drive using the engine powertrain**
- **No interruption in the power flow during gear changes**
- **Extremely efficient and high continuous output**

Rear power take-off. The U 400/U 500 can be equipped as an option with a rear power take-off in standard configuration for operating large, rear-mounted implements. With a continuous output of as much as 120 kW

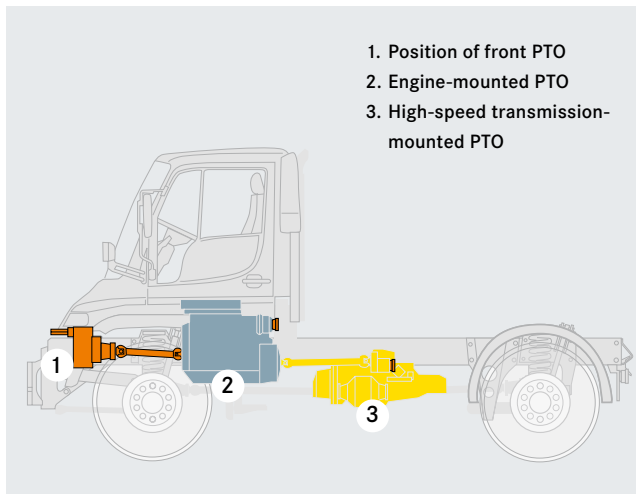

Unimog U 400/U 500: locations of front PTO (1), engine-mounted PTO (2) and high-speed transmission-mounted PTO (3).

and two PTO speeds (540 and 1,000 rpm), the rear power-take-off proves extremely efficient for operating wood chippers, large area mowers, loading trailers or balers.

- **Operated from control console in the cab**

Auxiliary drives. All power options included. The Unimog U 400/U 500 has both an engine-mounted and a transmission-mounted auxiliary drive. The engine-mounted auxiliary drive generally runs power hydraulics, but is also used to operate implements with hydrostatic drives such as verge or asphalt cutters with power hydraulics, designed by the implement manufacturer. The transmission-mounted auxiliary drive with standardised flange on the manual transmission is suitable for operating standard hydraulic pumps for cranes or aerial platforms. The output speed and direction of rotation are identical to the engine's speed and direction of rotation.



The socket to supply electricity for implements. Current collection up to 40 A.

- **Operated using pull switches in the centre console or as an option by remote control**

Parameterisable on-board electronics. Intelligent on-board powerpack. The parameter settings of the powerpack make straightforward, practical programming of the vehicle's basic configuration possible. From governing the engine speed or reverse shift lock to the engine start-stop function via remote control through the implement connector sockets. The result is maximum operational safety for man and machine. It also facilitates subsequent modifications when equipment or operating profiles are changed.

- **Practical basic settings for the on-board electronics can be programmed easily and individually**
- **Drivers are relieved of strain in critical driving situations**

Hydraulic Implement Drives and Hydraulic Implement Operation.

Depending on the job, the Unimog U 400/U 500 has an integrated dual-circuit hydraulic system or a high-performance dual-circuit hydraulic system at its disposal. This means that it has up to four completely independent hydraulic cycles available.

MBMANUAL







The power hydraulic connections are coded by colour and number – perfect for connecting implements quickly and without any error.



The gate-guided joystick gives you simple, convenient control over all implement movements.



The key pad shows the valves and connections arranged by colour and number.

Hydraulic design. Independent and versatile. The powerful hydraulic system is crucial to the high workload when operating multiple implements. With two circuits each in the working hydraulic and power hydraulic circuits, the Unimog U 400/U 500 allows a total of four hydraulic circuits to be used independently of one another at the same time – the ideal starting point for the Unimog’s versatile operations.

- Four hydraulic circuits – for outputs varying from 24 to 125 l/min and operating pressures from 200 to 300 bar
- Five basic hydraulic packages and additional hydraulic connections to choose from

Simple connection, straightforward operation. A few quick steps are all it takes. Hydraulic connections and plugs are coded by colour and number to expedite implement connection. Standardised couplings make it easy to swap implements. Plus, the floating position can be activated separately for each individual valve. The electric controls for the hydraulic functions are just as simple and are soon done intuitively.

- Key pad, hydraulic plugs and hydraulic connections coded by colour and number
- Electronic gate-guided joystick for controlling up to eight movements
- Rocker switch for valve selection
- Finger-operated buttons for activating the float setting or switching from connection one–four to five–eight
- Press switches for operating the permanent consumers (circuits III and IV)
- Emergency-stop switch for fast disablement of all valves

Working hydraulics. Made for all popular implements. Circuit I controls up to eight implement movements with a system pressure of 200 bar (24 l/min) via four double-acting valves, or it drives hydraulic motors running at low power. By combining circuits I+II (24 l/min + 48 l/min) together, implements can be actuated and hydraulic motors driven independently of one another. This provides you with a total of up to 240 bar and output for powering implements.

- Two independent hydraulic circuits: circuit I for controlling implement movements, circuit II for driving hydraulic motors
- Safe, convenient control of all implement movements
- Fitted ex works, reliable operation, spare parts supply guaranteed
- Changeover valve for flexible flow switching between circuits I and II or combining oil flow of circuits I and II

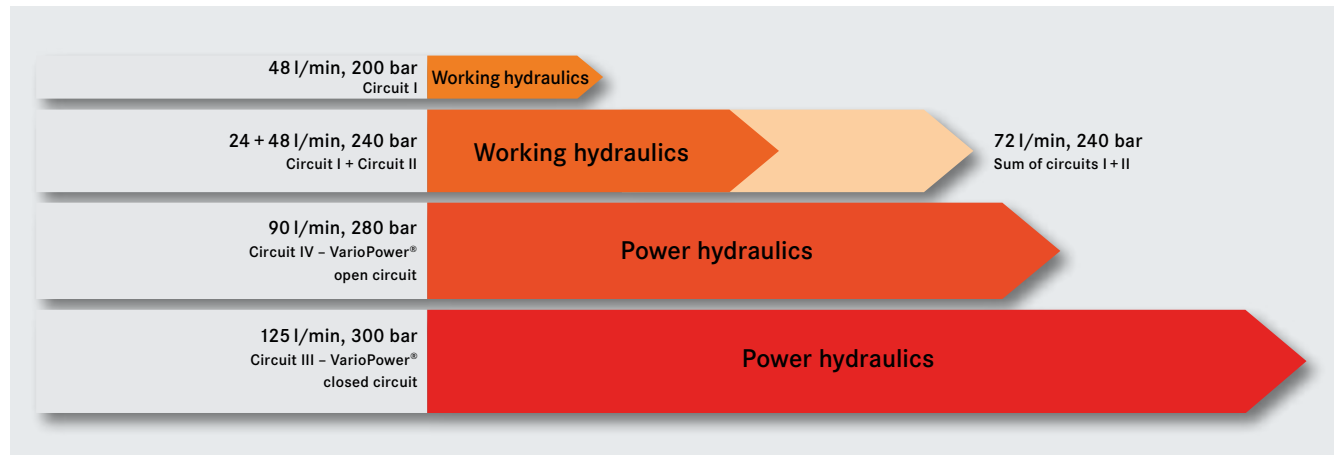

Power hydraulics. Power on tap. VarioPower® power hydraulics eliminates the need for separate hydraulic PTO pumps or diesel engines to drive implements. The open system (circuit IV) provides 42 kW, making it suitable for quickly discharging larger quantities of oil at high pressure or driving hydraulic motors. Maximum output is delivered by the closed system (circuit III): its 300 bar and 62 kW are sufficient for driving hydraulic motors in the upper capacity range.

- **Separate module in drop-side body sub-frame (can be removed together with body sub-frame to increase payload)**
- **Parallel operation of circuits III and IV allows two drives to be used simultaneously, saving time and costs**

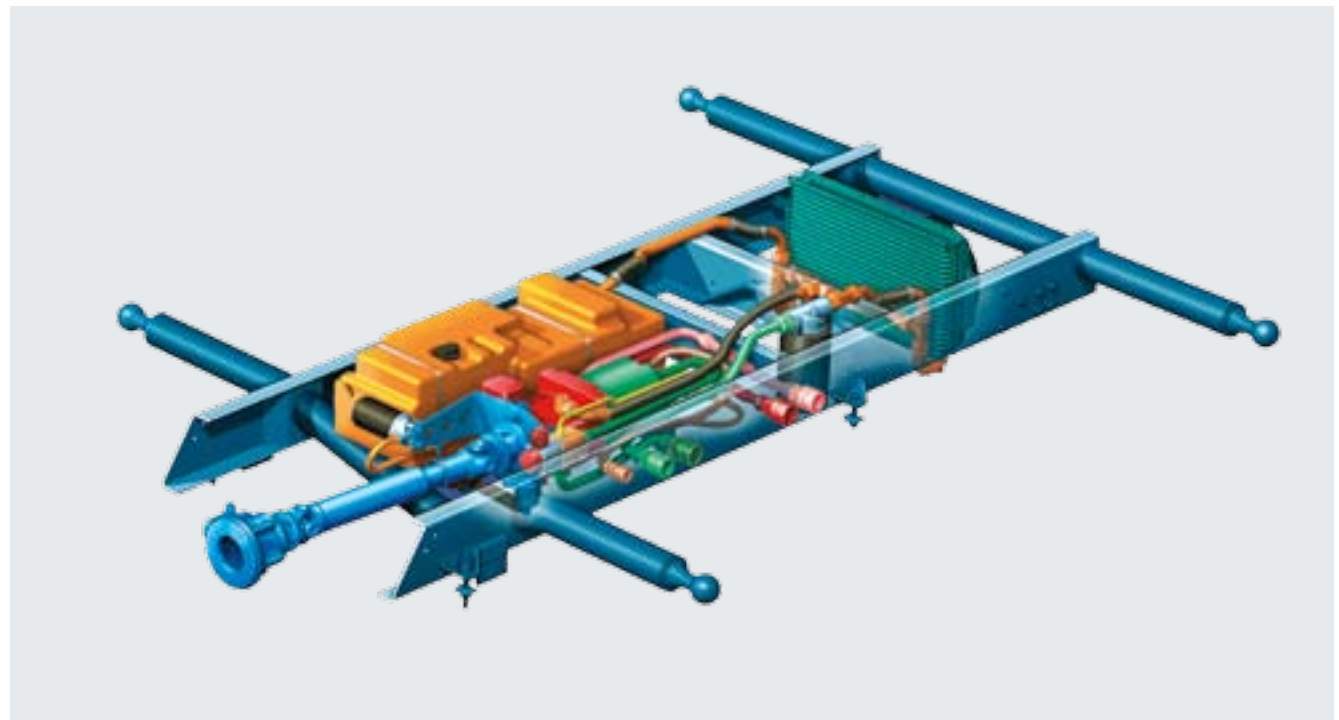

The VarioPower® power hydraulics are housed in the tipper body sub-frame and can be removed together with the sub-frame and implement if necessary.

Easy to Operate and Ergonomic.

The Unimog U 400/U 500 cab provides everything the driver needs to do his everyday work as ergonomically and safely as possible. And the combined air-conditioning, heating and ventilating system makes sure he always feels comfortable.

MBMANU



Taking the strain off the driver. Even when the job lasts a long time. The cab is made of non-corroding, noise- and heat-insulating high-tech fibre composite material (FVW). It is very strong and rigid and with sprung and damped mounting. As most of the functions are electrically controlled, the vibrations in the cab are reduced to a minimum.

- Generous headroom and room to move for relaxed working on long jobs
- Heating and ventilating system with integrated air conditioning
- Heating for seats, windscreens and mirror to make life easier in winter service
- Auxiliary heater, programmable
- Optional air suspension drivers seat

Ergonomic design. Clear and easy to use. The instrument panel is installed on the steering column. Perfect legibility is guaranteed no matter where the driver is seated. The backlit instrument panel and two LCD multifunction displays provide the driver with all relevant information. Whether driving or operating implements: all the controls and displays are found at a glance in functional groups on the central console, within easy reach and easy to understand.

- Instrument panel with visual and audible warning indicators
- Central console with clear and easy-to-reach operating elements
- Optional: Radio and CD-Player combination with Bluetooth and hands-free kit – for more safety whilst driving



Panoramic Cab.

See in advance what is coming. With its deep windscreen and steeply angled bonnet, the U 400/U 500 state-of-the-art panoramic cab offers an unimpeded view of the area in front of the vehicle, as well as of the coupling points or attached implements, thus increasing safety while working. Deep side windows combined with the large rear window and optional mowing door provide an outstanding all-round view of all working zones, when attaching and detaching implements or during operation for more safety.



The deep windscreen, deep-drawn side windows and the large rear window offer excellent and safer view to all sides.



The combined air-conditioning-heating-ventilating system ensures a pleasant interior temperature.

Compact dimensions. Maneouvable and exceptionally tough. With widths starting at 2.15 m, a compact front end of just 1.15 m and a turning circle starting at 13.7 m, the Unimog U 400/U 500 is ideal for working in confined areas. Further advantages over a truck include its multiple mounting areas and the higher load capacity of the front axle.

- **Manoeuvring and positioning with implements in confined spaces**
- **High front-axle load capacity for operating implements**



Mowing door and swivel seat for an unobstructed view and adequate legroom.



The VarioPilot® transferable steering can be slid from the left to the right side of the cab in an instant – ideal for safe and convenient one person operation.



Optional equipment. Geared to your requirements. Driver-oriented design has top priority for the Unimog U 400/U 500. This is clearly shown by the special options which ease day-to-day operations tremendously.

Three examples:

VarioPilot® transferable steering. The steering column including instrument panel and pedals can be easily moved from left to right. Drivers get the best view of the working area, can exit the vehicle on the side away from the traffic and enjoy easy one-man operation.

Mowing door. Instead of the standard co-driver's door, the Unimog can be fitted with an optional mowing door. With its enlarged panoramic side windows made of heat-insulated glass and wipers, it is perfect for mowing jobs, whether with one or two operators.

Swivel seat. The air-sprung swivel seat allows implements to be operated with ease, giving the best view of the work area to the right. The seat can be turned slightly for one-man operation or a full 90° for two-man operation. It is the ideal addition to the mowing door.

Economic Efficiency and the Environment.

The Unimog U 400/U 500 is not just ready for any situation or terrain, it is also designed for a long cost-effective working life. Its particularly clean BlueTec engines fulfil Euro emission standards and have impressively low fuel consumption. As fuel costs are always rising, you are not only caring for the environment, but also your finances. Thanks to the lower fuel consumption, CO₂ and particle emissions are also reduced substantially. The unique implement-carrying concept of the Unimog is rounded off by its reliability, long life span, economic efficiency and preservation of the environment thus making it a vehicle which looks ahead to the future.

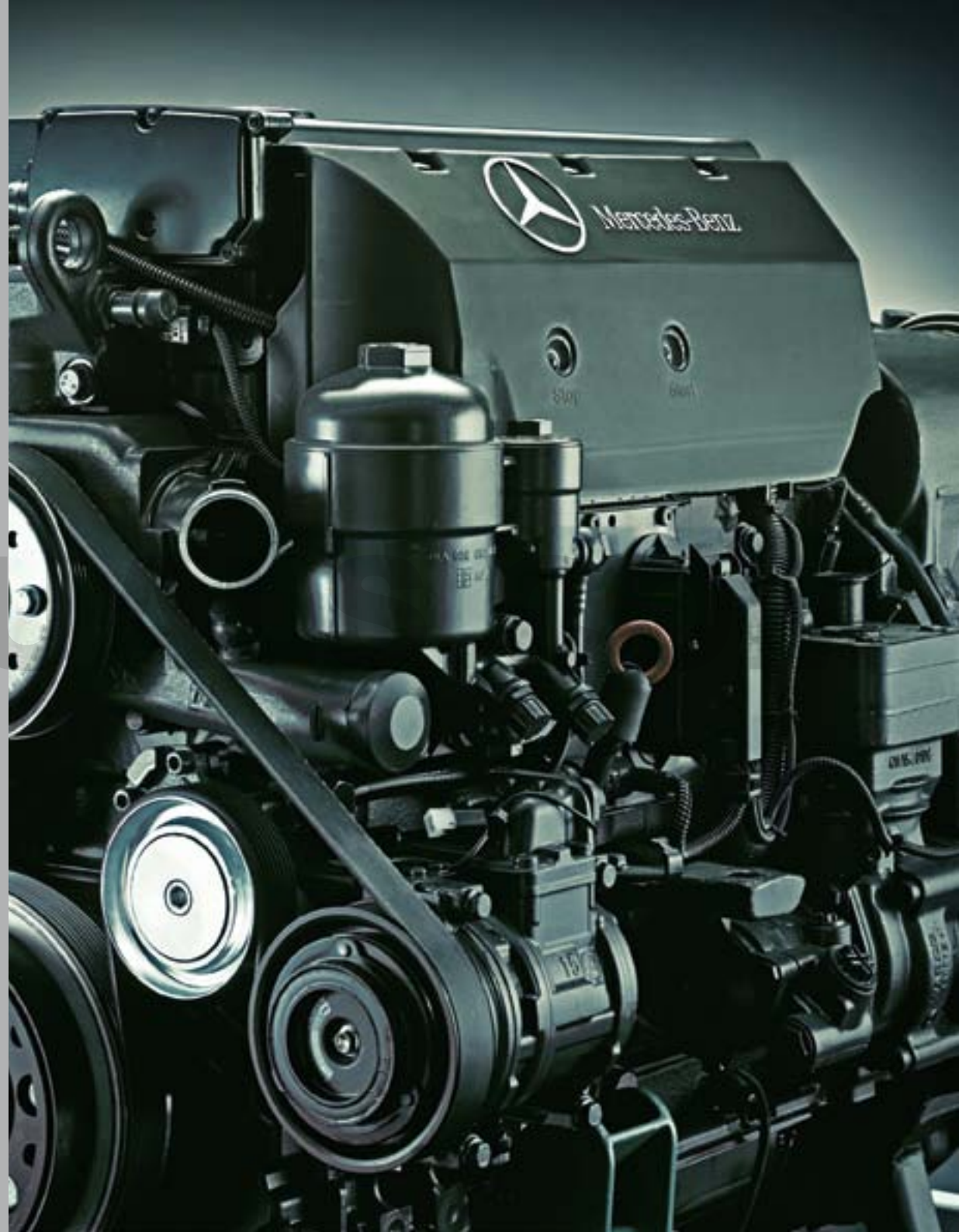

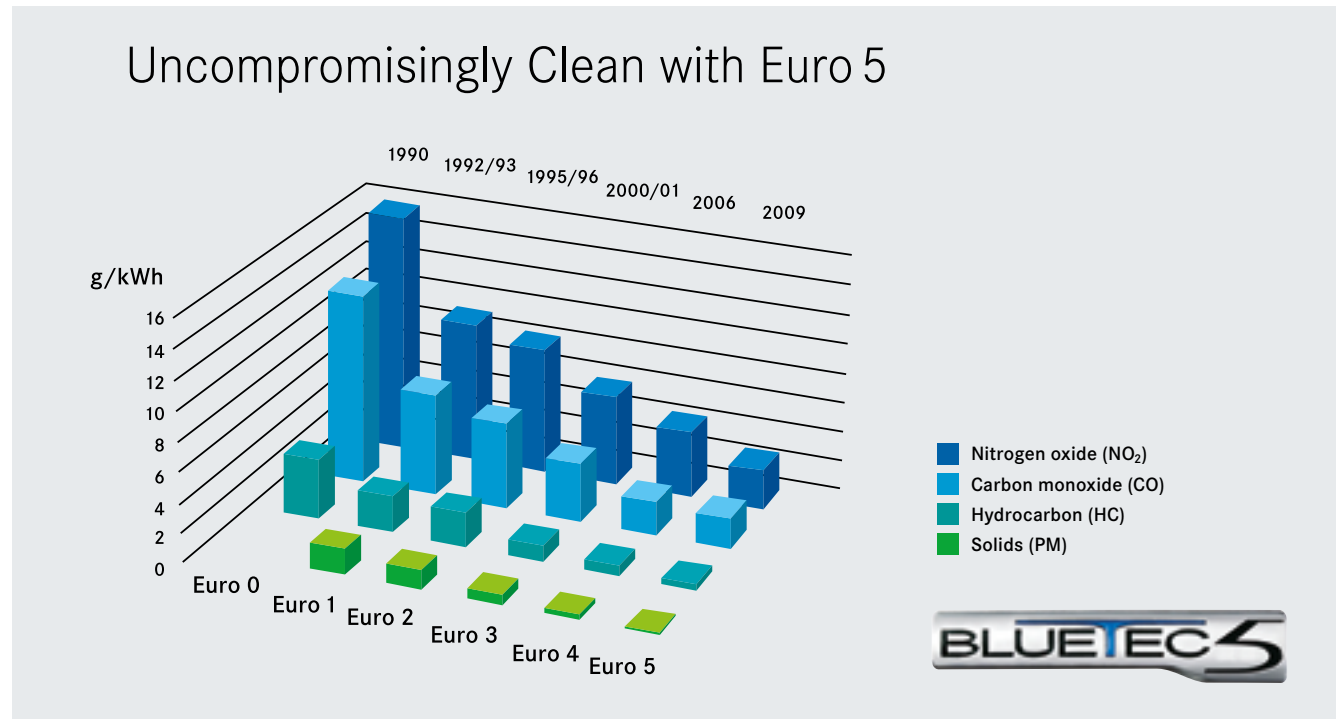

Clean, safe, economical. BlueTec diesel technology.

BlueTec is the new SCR (Selective Catalytic Reduction) diesel technology from Mercedes-Benz. It lowers nitrogen oxide and particle emissions significantly as well as optimising fuel consumption, without any loss of engine power. An extra catalytic converter reduces the nitrogen oxide levels using the additive AdBlue, a non-toxic aqueous solution which is fed from a separate tank. Apart from fulfilling the European Union’s strict directives for reducing vehicle emissions, the Unimog also offers a low wear and tear and low maintenance system. Plus engines with a higher power output (depending on the model). Thus a future-proof solution is guaranteed.

Adaptable engine management. The driving and working mode. The engine characteristics can be adjusted individually to suit the operating mode at the touch of a button. In the driving mode on roads or for transporting loads, you benefit from its flexible torque. The working mode ensures minimal rpm speed deviations when operating implements or driving off-road, even with fluctuating loads.

Always ready to give peak performance. The low-maintenance Euro 5 engines from Mercedes-Benz are state-of-the art in every respect and perfectly equipped for a wide variety of tasks. From their direct injection and three-valve technology, turbocharger and intercooler, to their steep torque curve, constant output over a wide rpm range and high power reserves. The combustion-air intake

is positioned where dust levels are lowest. The thermostat-controlled radiator with hydraulic fan keeps the engine cool, even at low vehicle speeds and high working performance. The large modular cooling system with its open-order design is very maintenance-friendly due to the removable cleaning grill which means that the Unimog U 400/U 500 has no difficulties when working in extremely dusty conditions.

- **Low-maintenance engines from 130 kW (177 hp) to 210 kW (286 hp)**
- **Low-emission, economical and quiet-running**
- **Sharp reduction in nitrogen oxide and particle emissions**
- **Improved combustion efficiency**
- **Reduced fuel consumption**



BMW

After-sales service.

We are there, wherever you are.

You can go anywhere with a Unimog – and that is why we are also waiting for you everywhere you go. At more than 650 Unimog Service Centres worldwide we can attend to your Unimog – if necessary immediately – with the same care, the same experience and the same technical means we used to build it. And of course we only use spare parts which come up to our strict standards regarding quality and availability.

Your advantages at a glance:

- ✓ Worldwide service network
- ✓ Personal and flexible customer care
- ✓ After-sales support directly from manufacture to customer
- ✓ Service and maintenance for both vehicle and implements
- ✓ Made-to-measure service products
- ✓ High quality and readily available Mercedes-Benz GenuineParts

Financial services.

Customised solutions to suit your needs.

A professional fleet and financial concept is the basis of your success. Your capital should continue to be as available as your vehicles. And this is where the Unimog system and its financial services can make a considerable contribution. We can offer you economically efficient financing and leasing models at reasonable conditions which are individually designed to suit your own requirements.

Your advantages at a glance:

- ✓ Reasonable conditions
- ✓ Flexible terms
- ✓ Guaranteed fixed interest rates
- ✓ Individual consultations
- ✓ One-stop-shopping from your Unimog retailer



You want to get things moving? You have got to know the Unimog U 400/U 500 in this brochure. With its unique off-road capabilities, the Unimog U 4000/U 5000 beats every competitor hollow with its convincing features such as the flexible ladder-type frame for great stability when driving on the road and enormous torsional flexibility when driving off-road, its superior all-wheel drive with differential locks in both axles and its portal axles for especially high ground clearance.

Do you have any questions, comments or suggestions on the topic of Unimog? Or want to know what the Unimog can do for you? Then don't hesitate to contact us. We are looking forward to hearing from you!

Concerning the details in this brochure: the products may have undergone slight changes after the editorial deadline of this brochure. We, the manufacturers, reserve the right to make any constructional changes, design alterations, colour modifications as well as changes to the scope of delivery during the delivery period, as long as the changes or modifications are not unreasonable for the customer. The salesman and/or manufacturer are not legally bound as long as they describe the order or the ordered articles with symbols or numbers. The pictures in this brochure may also contain accessories or special fittings that do not belong to the standard scope of delivery. Colour modifications are due to typographical causes. This printed matter may also contain models and customer services that are not available in individual countries. Statements concerning statutory, legal and tax regulations and the implications thereof are only valid for the Federal Republic of Germany prior to the deadline of this brochure. Please consult your Unimog Partner with respect to the latest binding regulations and stipulations and their implications. www.mercedes-benz.com/specialtrucks