



Mercedes-Benz

The Unimog U 20

The Unimog Concept

Getting through where others give up

Where even four-wheel drive trucks reach their limits and tractors can't go any further, a totally new kind of work and tractor vehicle has to take over: the Unimog. It gives an absolutely new definition of versatility and viability on four wheels. The Mercedes-Benz Unimog is a vehicle in a league of its own. It provides solutions which no other vehicle worldwide can offer. The Unimog is much more versatile than any other with its attachment and mounting areas at the front, middle and rear. It is also much more at home on off-road terrain than any other vehicle, and can drive at fast speeds on roads as a transporter. The Unimog is an uncompromising professional for uncompromising professionals. Superior in every situation and over any terrain.

Contents:

The U 20 Model Range	4-5
Forward Control Cab	6-7
Chassis Expertise	8-11
Vehicle Drive	12-13
Mechanical and Hydraulic Implement Drives	14-17
System and Implement- Carrying Expertise	18-21
Easy to Operate and Ergonomic	22-23
Economic Efficiency and the Environment	24-25
Worldwide Service	26-27
Looking to the Future	28-29





Can do what bigger ones can't

As a universal implement carrier with a maximum weight of up to 7.5/9.3 t, the Unimog U 20 is the perfect answer for all municipal maintenance work. It doesn't cost any more than a high-end municipal tractor, has all the advantages of a four-wheel drive truck, but with a much smaller turning circle, and the power reserves of a genuine Unimog. To sum up: maximum all-year-round utilisation at an unbeatable price.

Forward Control Cab

With its short forward control cab, short wheelbase, compact width and low overall height, the Unimog U 20 is especially manoeuvrable. Perfect for municipal work.

MBMANU





Short wheelbase, compact dimensions: the Unimog U20 is very manoeuvrable even in the most confined spaces, but still has a large frame for mounting implements



Compact Dimensions. The smallest and most manoeuvrable Implement Carrier in the 7.5/9.3 t Class. With its compact wheelbase, 38 cm shorter than the Unimog U 300, the Unimog U 20 has a turning circle of only 12.6 m, is able to drive under low bridges with its overall height of 2.7 m – and still has enough room for a 2.2 m long drop-side body. Exactly what you need for efficient all-year-round municipal maintenance work.

- Manoeuvring and positioning with implements in confined areas
- Large body-mounting area on a very short wheelbase

Forward Control Cab. Very compact and corrosion-resistant. The compact and low galvanised-steel forward control cab is mass-produced – one of the reasons why the Unimog U 20 is so outstandingly cost-effective. Plus, it is corrosion-resistant – perfect for winter services. And not only that: driving through extremely narrow streets seems like child’s play. And, thanks to the driving seat over the front axle and the shock-mounted cab, it gives a very comfortable ride.

- Front mirror and low dashboard minimize the blindspots when operating implements
- Galvanised steel to provide high corrosion resistance
- Cab can be tipped forward to make maintenance work easier

Chassis Expertise

Where others get wheelspin, the Unimog U 20 really gets going. With its portal axles, permanent four-wheel drive and off-road gearing, the U 20 is a match for any terrain and accepts every challenge.

MBMANUA





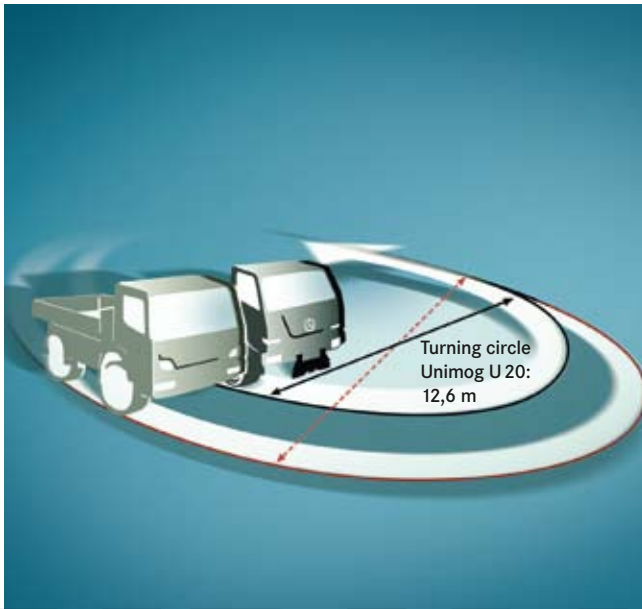

With a turning circle of only 12.6 m, the Unimog U 20 beats any four-wheel truck

Turning Circle. Clearly superior to any truck. With a turning circle of only 12.6 m and a wheelbase of only 2.7 m, the Unimog U 20 beats any four-wheel drive truck. And with a width of only 2.15 m, it gets through where trucks and tractors capitulate.

- Easier positioning, manoeuvring and turning – all due to a short wheelbase and a 12.6 m turning circle
- Ideal for local authorities, gardening and landscaping firms



Outstanding off-road performance due to its axle articulation, permanent 4WD and manually engageable locking differentials in both axles

Permanent Four-Wheel Drive. Maximum Traction. The standard permanent mechanical four-wheel drive provides excellent traction and directional stability, especially in winter. To gain maximum traction, the longitudinal differential and both axle differentials can be locked while driving, simply by activating a switch and without interrupting tractive power.

- A minimum of wear and tear
- Excellent directional stability and safety during winter service
- 100% locking of both axles for non-slip power transmission to all 4 wheels

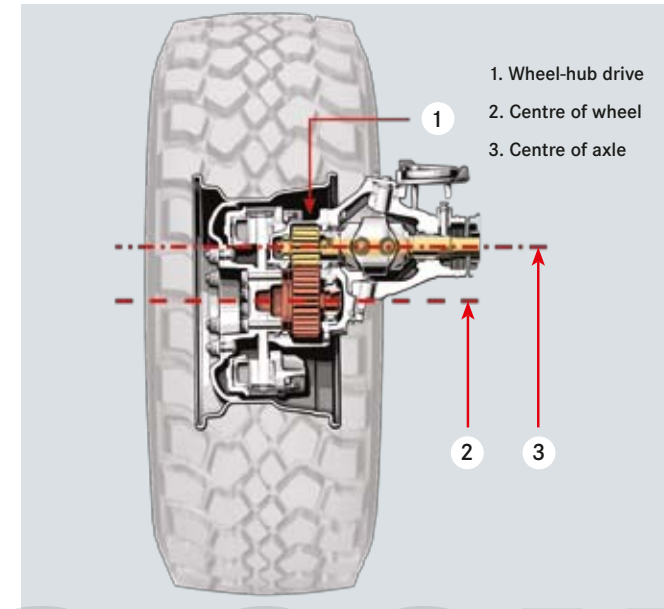

Portal axles provide outstanding ground clearance over difficult terrain

Portal Axles. Cope with any kind of Terrain. Portal axles give the Unimog U 20 its outstanding ground clearance for difficult off-road conditions and – thanks to its high maximum axle load – even with attached or mounted implements. The axle steering guide with integrated anti-roll bars ensures stable handling, has only slight roll and pitch and excellent directional stability during spring extension and compression.

- High front axle load for operating implements
- Good cornering characteristics even when fully laden
- High ground clearance with a low vehicle centre of gravity

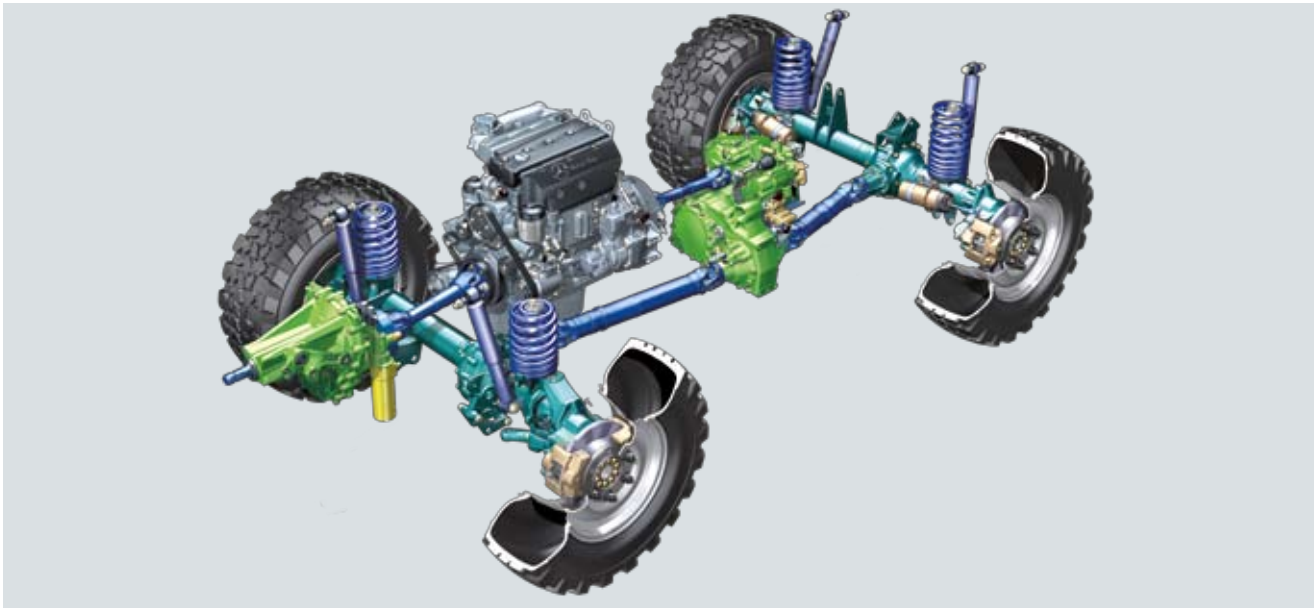

Mounted bodies are well cushioned – due to coil springs and telescopic shock absorbers

Coil Springs. Keeping four wheels on the ground. The progressive extension of the coil springs with telescopic shock absorbers give the narrow vehicle the greatest possible stability. Their long spring shock courses and great axle articulation ensure that all 4 wheels have ground contact even off the road.

- Great comfort while driving
- Minimal self-steering properties
- Optimal suspension adaption to all kinds of loads

Single Tyres. Many Uses. Unlike normal four-wheel drive trucks with twin tyres on the rear axle, the Unimog has single tyres. This means that the rear wheels run in the compressed track of the front wheels, thus ensuring high traction with only minimal rolling resistance.

- For winter services or difficult off-road terrain, chains can be mounted according to tyre size



Even more safety due to the disengageable anti-lock braking system (ABS)

More Intelligent Braking with ABS and ALB. The standard anti-lock braking system increases safety and driving stability. It guarantees directional and driving stability as well as a short braking distance. It can also be switched off when driving off-road. The automatic load-sensitive braking system (ALB) makes sure the Unimog brakes steadily according to its load.

- More safety through excellent driving stability and steering ability
- ABS control for each individual wheel
- ALB – braking force control depending on load

Vehicle Drive

With the U 20 you really get going. And have the right amount of power for the job on hand. Even with heavy loads or at a snail's pace – and with no slipping clutches. That is low on wear and tear and also good for your nerves.

MBMANUAL



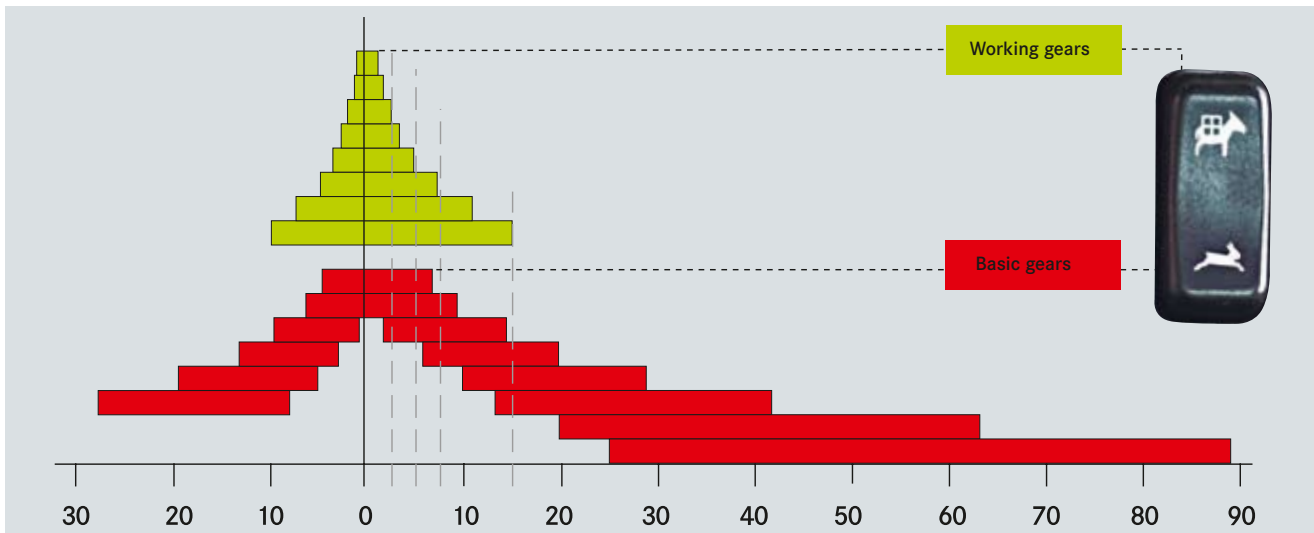

A total of 16 forward and 14 reverse gears provide you with the optimal working and driving speeds for every job

Transmission. As versatile as you need it to be. The fully synchronised electro-pneumatic transmission (Telligent®) with up to 16 forward and 14 reverse gears is renowned for its extremely smooth running, long life span, great efficiency, and the versatility to deal with a wide variety of jobs. The synchronised quick-reversing system EQR makes it easy to change directions quickly, for instance when clearing snow.

- Low fuel consumption and strong for the job – at speeds of 1.2 to 90 km/h
- Direct, fast gear shifting when clearing snow and manoeuvring

Working Gears. Full Power at any Speed. The basic gears can be easily supplemented for the job on hand. 8 heavy-duty working gears increase the speed range according to the job you are doing and also the tractive power.

- A total of 16 forward and 14 reverse gears allow you to adjust your speed according to the job at hand
- The rocker switch allows you to initiate the basic and working gears electro-pneumatically

Telligent® Gearshift. Changes faster than you can think.

Tap the gearshift lightly to front or rear – and immediately the Telligent® system calculates the torque and, depending on the engine speed, the following gear – which is subsequently shown on the display. If you agree, you only have to press the clutch. Otherwise, simply select the gear you want manually.

- Easy on the engine, clutch and gears
- When shifting gears, the right hand is free – for instance, to operate implements
- Relaxed, concentrated driving



The quick-witted gear shift. Touch the gear and press the clutch

Parameterisable On-Board Electronics: Intelligent Power Plant on Board. The parameter settings of the on-board electronics can be customised simply to suit your needs. From governing the engine speed or reverse shift lock to the engine start-stop function via remote control through the implement connector sockets.

- Practical standard settings can be simply and individually stored in the on-board electronics
- Less strain on the driver in critical driving situations



Mechanical and Hydraulic Implement Drive

The Unimog U 20 gives a versatile performance in any situation and the implement drives can be operated safely and intuitively. Their output can be dosed exactly to suit your requirements.

MBMANU





The engine-driven front PTO drives implements which need a great deal of power

Front Power Take-Off (PTO). A Plus for driving Implements.

Implements needing a lot of power can be operated directly via the powerful engine-driven front PTO. Its output: the full engine performance (110 kW/150 hp). The standard oil-cooled 1 3/4" spline profiled PTO provides high torque with an extremely efficient performance. Due to the rpm indicator and electronic engine control, the PTO rpm can be finely adjusted between 420 and 1,000 rpm: exactly and infinitely variable.

- Direct mechanical drive from the powertrain
- No interruption of power flow when shifting gears
- Extremely efficient and high continuous output

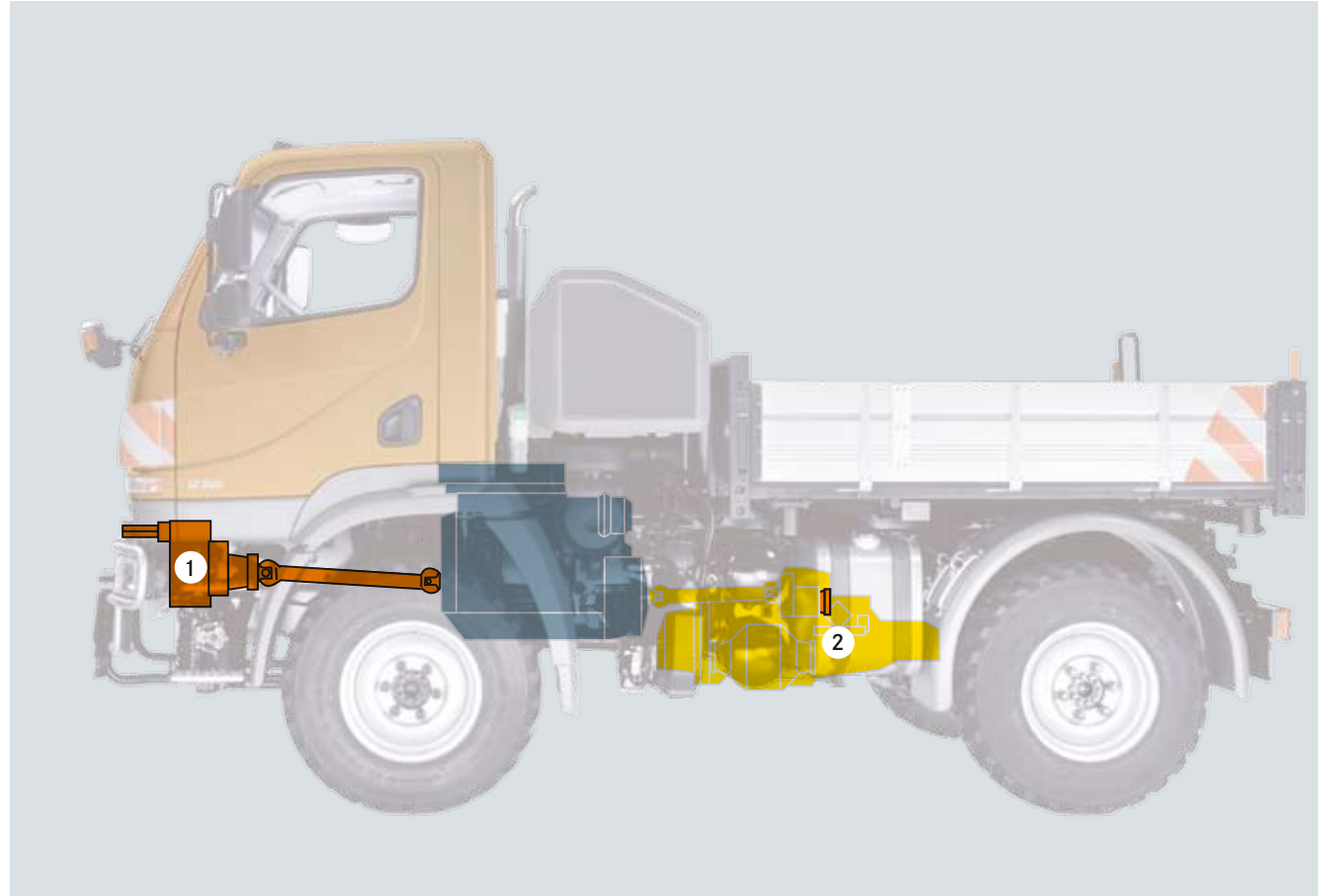

The position of the front PTO (1) and fast auxiliary drive (2) on the Unimog U20

Auxiliary Drives. Getting the correct rpm. Commercial hydraulic pumps, e.g. for cranes, can be operated using various adapters in combination with the auxiliary drive. The rpm speed (i = 1) and the direction of rotation of both engine and auxiliary drive are identical.

- Operated by pulling the switch in the central console



Hydraulic couplings are colour-coded – ideal for attaching implements quickly and safely

Hydraulic design. Independent and versatile. The powerful hydraulic system of the Unimog U 20 plays a vital role in its outstanding versatility. The basic package includes 2 hydraulic circuits and a standard snowplough relief which is absolutely indispensable when operating a snowplough, gritter or mower. Additionally, the tipper body can be fitted with an extra tipping cylinder, making the Unimog hydraulic system an indispensable assistant for all municipal maintenance work throughout the year.

- 2 hydraulic circuits with 24 or 48 l/min and 200 bar working pressure
- Flat sealing, non-dripping hydraulic connectors

Hydraulic Connectors. Simple and fast to connect. Colour- and number-coded hydraulic connectors make attaching implements easy and fast. Standardised connectors make changing implements child's play. And the float position for each valve can be adjusted individually. The electronically controlled hydraulic functions are just as simple and are soon done intuitively.

- Key pad, hydraulic plugs and connectors are colour and number-coded
- Electronic gate-guided joystick for controlling up to 6 movements
- Buttons for activating float setting or to switch connections
- Emergency-stop switch for fast valve disablement



All implement movements can be easily and simply controlled with the joystick

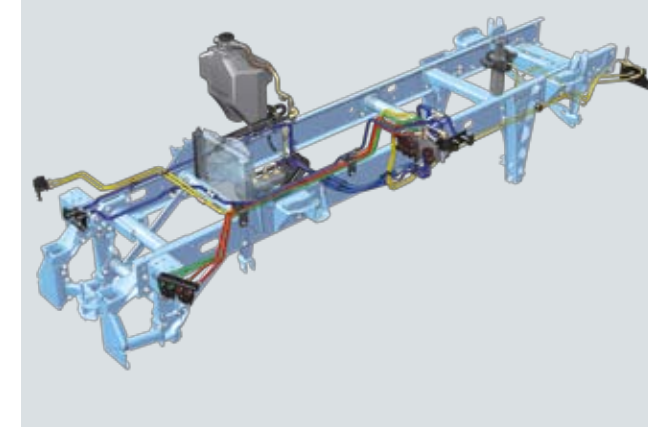

The hydraulic system for operating implements has 2 independently functioning hydraulic circuits. If necessary, circuit I and circuit II can be exchanged or combined



As a result of years of cooperation with leading implement and body manufacturers, the exceedingly powerful hydraulic system suits standard municipal implements perfectly

Hydraulic System. Perfectly equipped to drive standard Implements. The package has 2 hydraulic circuits. Circuit I uses 3 double-acting valves with 200 bar system pressure to actuate up to 6 implement movements or to operate hydro-engines in the lower performance range (up to 24 l/min). Circuit II supplies permanent consumers, such as gritters, with a flow rate of up to 48 l/min – independently of circuit I. With change-over valve (X), the flow rate for circuit I and circuit II can be exchanged, so that there are 48 l/min available for the circuit I connectors. This means that fast snowplough movements can be made even when driving slowly. In the same way, with combination switch (Y), the flow rate of both circuit I and circuit II (24 + 48 l/min) can be combined, so that circuit II has 72 l/min available for implements consuming a great deal of power.

- 2 hydraulic circuits operating independently: circuit I for activating implement movements, circuit II for equipment with continuous operation
- Safe, easy control of all movements
- Integrated ex works, safe to use, spare parts always available



Set up for winter service – from the superior chassis to integrated snow plough weight transfer



Winter Service. Superbly equipped for below-zero temperatures. During the coldest winter, the Unimog is always ready for action. Thanks to such plus points as its heavy-duty battery for reliable starts, heated air dryer for the braking system or engine preheating.

System and Implement-Carrying Expertise

One for almost all. With its 2 attachment areas and 1 mounting area, the Unimog U 20 has a uniquely versatile platform with 3 positions for various implement combinations for a multitude of purposes. That is what makes it so cost-effective for all-year-round work.

MBMANUA





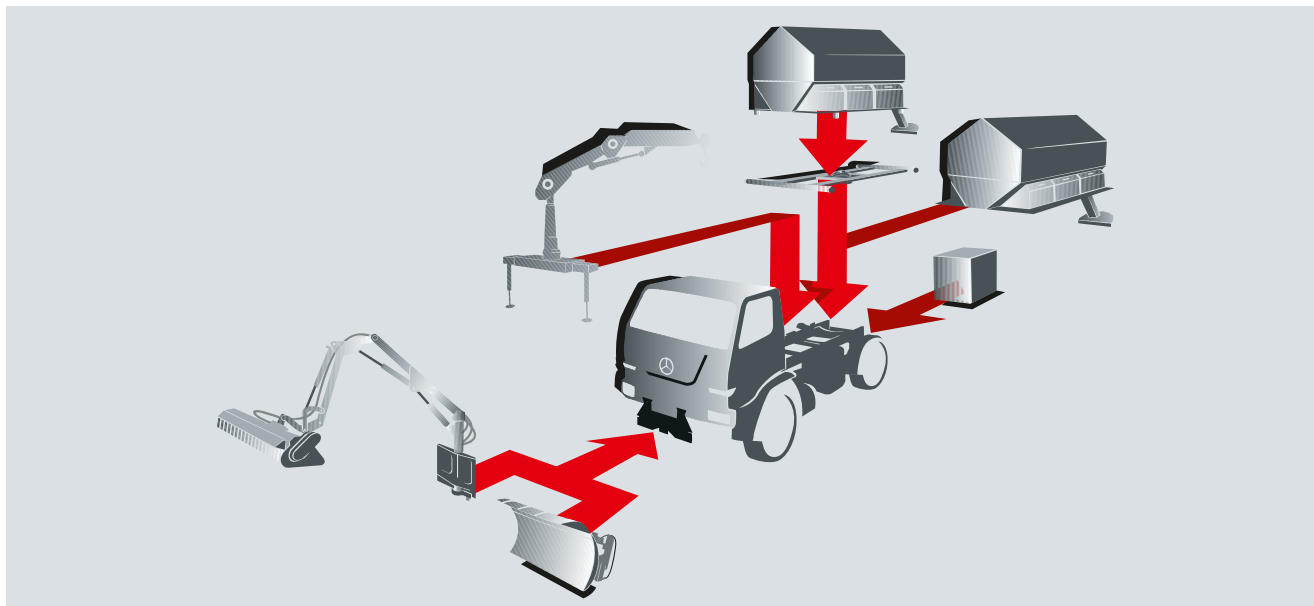

The Unimog U 20 attachment and body mounting areas are designed for cost-effective all-year-round municipal maintenance jobs

2 Attachment Areas: More efficient Operation. One at the front, the other at the rear. They allow the Unimog U 20 to be equipped with a large variety of implements, so that several tasks can be dealt with simultaneously – quickly, easily and economically.

- Front attachment area with standardised front attachment plate (e. g. for snowplough, verge mower, sewer flusher, wood chipper)
- Rear attachment area (e. g. for quick-change smaller rear cranes, rear power lift or gully cleaning system)

1 Mounting Position, 3 Possibilities: Always the right Solution. With or without a drop-side body they make the Unimog U 20 extremely versatile. If necessary, the drop-side body can be removed from the tipping cylinder to permit a higher payload.

- Existing implements can be mounted onto the drop-side body
- Newer implements can be mounted directly onto the ball-mounting positions of the drop-side body sub-frame (additional payload gained by removing drop-side body)
- Permanent bodies or seasonal implements can be mounted directly onto the lengthwise supports of the frame



Permanent four-wheel drive, locking differentials in the axles and single tyres with snow chains ...



... the Unimog U 20 deals easily with winter services both on country roads and in the confines of the city

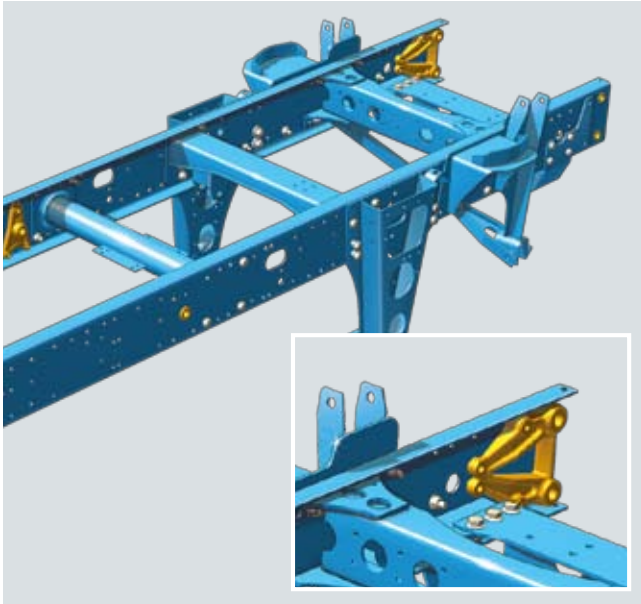

A continuous, robust ladder-type frame with integrated mounting positions makes attaching implements simpler

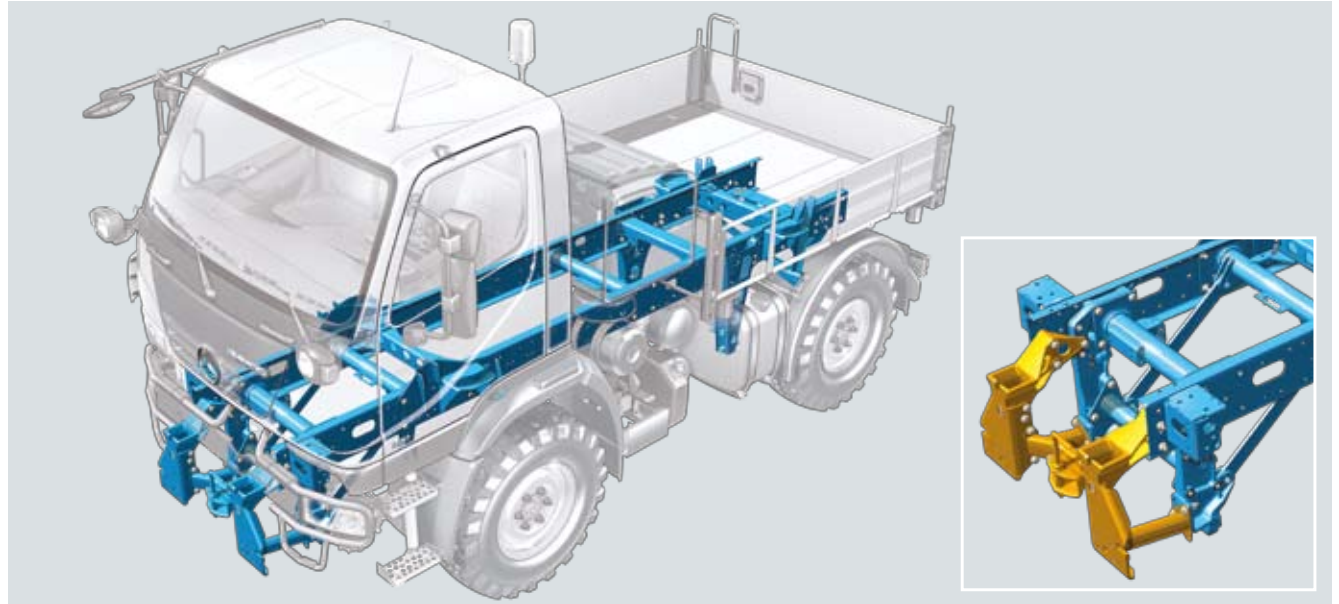

Rear mounting brackets for simple implement mounting



Sturdy front mounting plate for verge mowers, snowploughs or similar implements

Frame Design. Safe, cost-effective, robust. The basis for the cost-effective all-year-round operation of the Unimog U 20 as a professional implement carrier is its continuous, straight ladder-type frame. It simplifies mounting existing or newer, even more efficient implements. Its outstanding rigidity and torsional resistance ensure maximum stability. The integrated mounting positions and hole patterns simplify attaching and mounting and provide additional safety even during extreme operations.

- Simple, direct implement mounting on the longitudinal tubular frame supports
- Good handling characteristics at maximum thrust and traction, with or without implements
- Designed for attaching several implements at the same time, up to 9.3 t max. weight

Defined Attachment Points. Simple and quick Mounting. On the Unimog all necessary attachment points are pre-installed on all attachment and mounting areas, and are compatible with existing implements.

- Developed ex works and coordinated with implement and body manufacturers
- Simple mounting
- Defined power feed
- Protected against overloading

Easy to Operate and Ergonomic

The Unimog U 20 cab provides everything to make the working day for both driver and co-driver as ergonomic and safe as possible. Air conditioning is available as an option to provide a cosy atmosphere in any weather.

MBMANU





Comfortable cab entry in front of the front axle

Comfortable Working Conditions. Fatigue-free Working.

One of the basic Unimog U 20 principles is to take the strain off the driver. It starts off with an easy cab entry in front of the front axle (with a wide door-opening angle of almost 90°), 3 seats (standard), plenty of room to move and an individually adjustable steering column. That's good to know at the start of a long working day.

- Generous headroom and freedom of movement for relaxed working conditions during a long day's job
- Optional integrated air conditioning
- 3-stage adjustable roof hatch for good ventilation
- Standard power windows



Comfortable: the forward control cab with wide door-opening angle and 3 seats

Ergonomic Design. Clear and simple to operate.

Ease of operation ensured by adjustable light for the instrument panel, information display for the driver, multifunction levers on both sides of the steering column. Whether driving or operating implements: all controls and displays visible at a glance on the central console, arranged according to function, well within reach and easy to understand.

- Integrated professional joystick for implement controls
- Central console with clearly visible and easy-to-reach controls



The multifunction lockable box provides a lot of space for shovels, small implements or snow chains

Multifunction Box. A lot of Room for your Equipment.

The compact forward control cab not only leaves enough room for a 2.2 m drop-side body. Behind the cab, as an option, there is enough space to fit an integrated, lockable multifunction box with 5 removable inserts to stow your materials safely. This means that shovels, small implements, snow chains and other tools are always easily accessible.

- Lockable multifunction box
- Additional storage space for equipment
- Made of weather-resistant plastic

Economic Efficiency and the Environment

The Unimog U 20 is designed not only for any situation and any terrain, but also for a long, economically viable life. Reliability, a long life span, and environmental sustainability supplement its unique implement-carrying expertise as a forward-looking vehicle. It would be hard to find its equal.

MBMANU

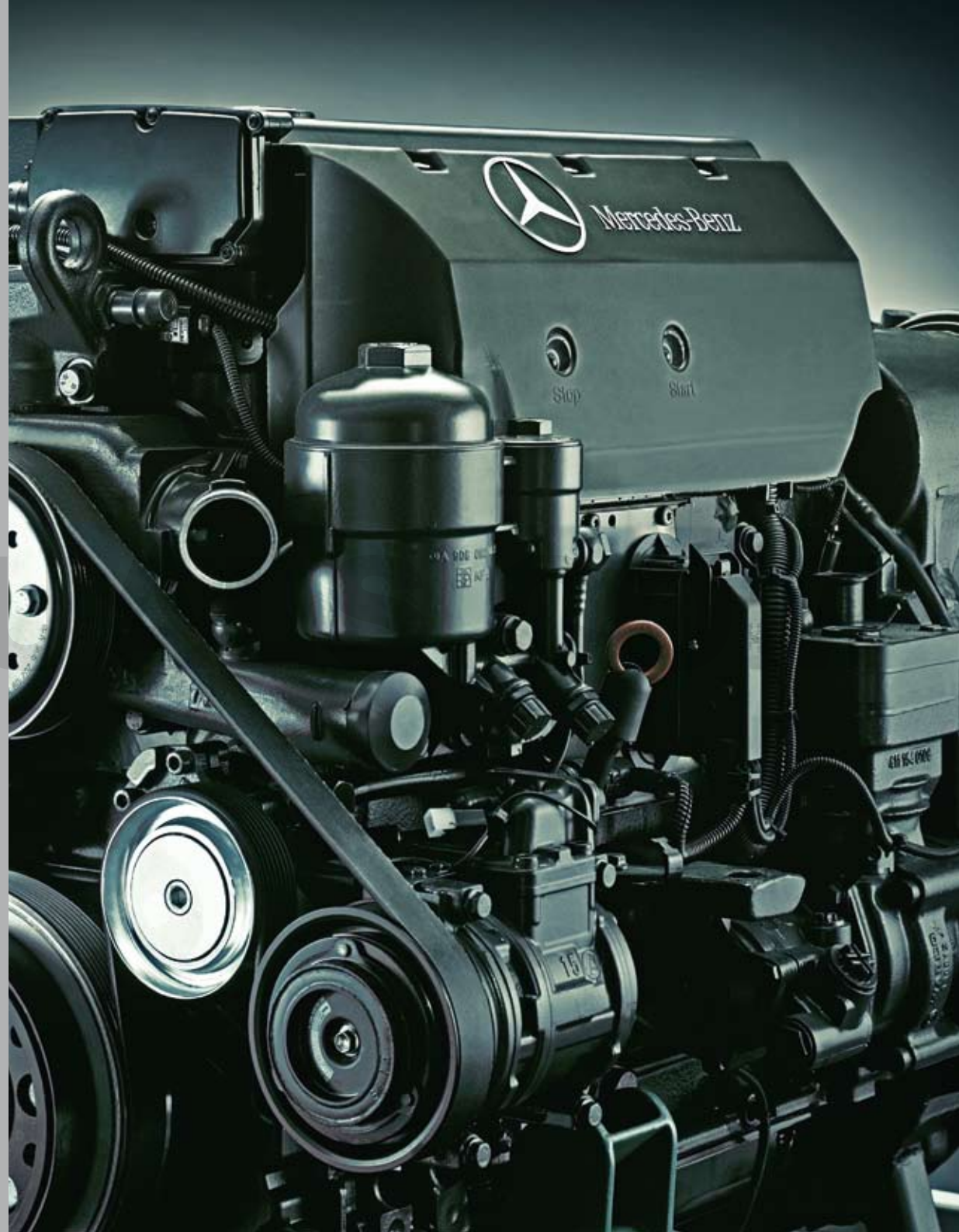



Compact: the additional AdBlue® 25 l tank

Engines. Always prepared to give the max. The low-maintenance Euro 4 (from 2009: Euro 5) engines from Mercedes-Benz are state-of-the-art in every respect. From their direct injection and 3-valve technology to exhaust turbocharger, intercooler and steep torque curve to constant output over a wide rpm range and high power reserves. The combustion-air intake is positioned where dust levels are lowest. The thermostatic-controlled radiator with hydrofan keeps the engine cool, even at low speeds and high working performance. The large radiator system with its removable cleaning grill is especially maintenance-friendly.

Driving and Working Modes. Engine Regulation as desired. Depending on the type of job, the engine characteristics can be individually altered at the touch of a button. The driving mode gives you an elastic speed range. And the working mode has minimal engine speed deviations, e.g. when operating implements even with varying loads.

BlueTec® Clean, safe, economical. BlueTec® is the new SCR diesel technology (selective catalytic reduction) from Mercedes-Benz. BlueTec® drastically lowers both nitrogen oxide and particle emissions, while optimising fuel consumption without reducing the performance of the diesel engine. An additional catalytic converter reduces the nitrogen oxide with the additive AdBlue®. This chemically non-toxic aqueous solution is added from a separate tank. This way, the Unimog U 20 complies with strict European Union standards to reduce vehicle emissions, and it has received the green “particle emissions” sticker entitling it to drive through all environmentally sensitive city zones. An important advantage for municipal vehicles.

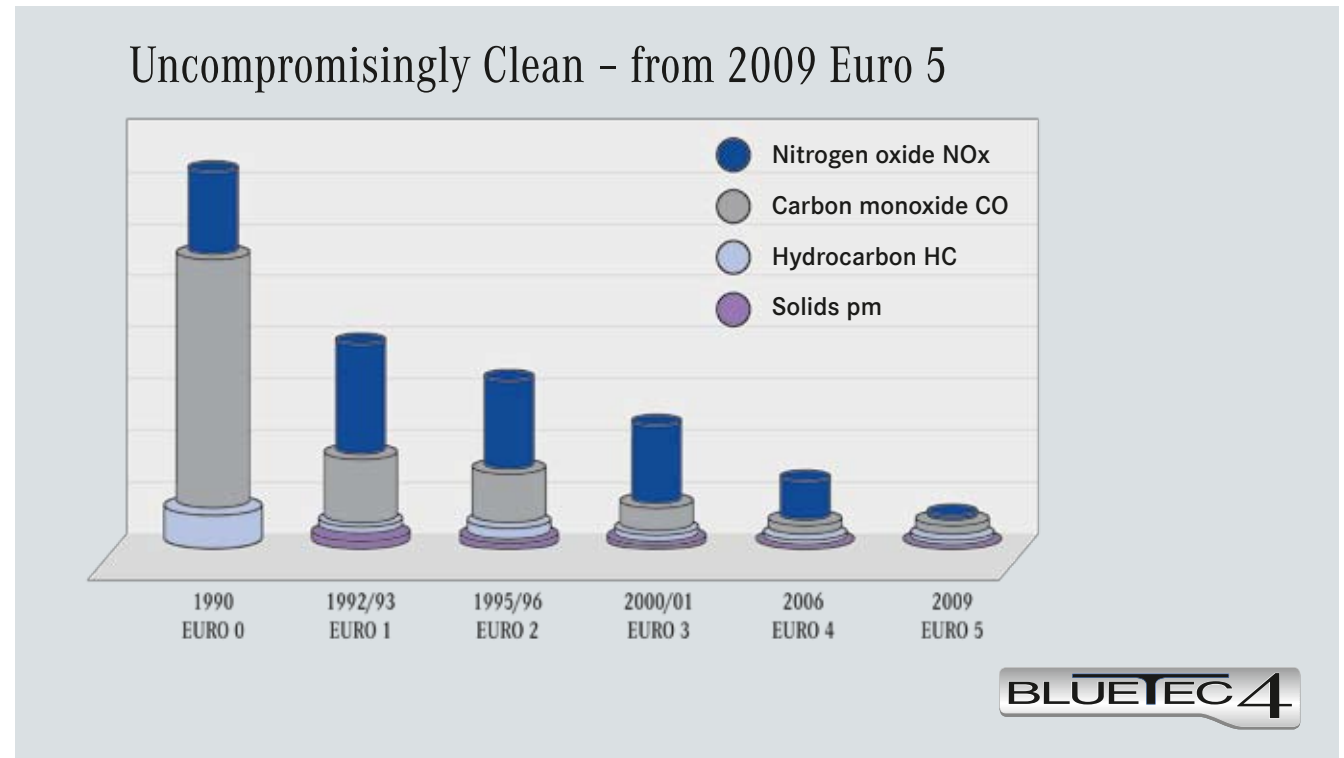



Always Close By

Worldwide Service from Mercedes-Benz

Where there is a Unimog on the road, then we are not far away. Thanks to more than 1,000 service stations worldwide, your Unimog Partner is easy to reach when you need him. With vehicle maintenance and other services which are just as reliable, flexible and progressive as the Mercedes-Benz Unimog itself. From our fast spare-parts service to repairs and maintenance up to a made-to-measure financing or leasing offer. And not just for your Unimog itself, but also for a whole range of bodies and implements. You can rely on us.

Would you like to find out more about the Unimog? Then simply detach the postcard, fill it out and send it off. Or send us the postcard by fax: +49 (0) 721 1510125.

Other information and the current Unimog eNewsletter are available on the internet at:
www.mercedes-benz.com/unimog

You can order the eNewsletter by using the postcard. Simply enter your e-mail address on the reverse side and then you will always be up-to-date.





Looking to the Future

You want to get things moving?

With the Unimog, you get much more than just a truck. The Unimog is a philosophy come true. There is hardly a sector or situation to be imagined where the Unimog cannot be used successfully – it has proved this for decades. For very diverse tasks and needs, there are 3 model ranges to choose from.

You have got to know the U 20 in this brochure.

As professional Implement Carriers over 7.5 t max. weight, the Unimog U 300/U 400/U 500 provides unrivalled top performances. Especially for professionals who want to combine outstanding performance with economic efficiency in all-year-round service.

With its unique Off-Road Capabilities, the Unimog U 3000/U 4000/U 5000 beats every competitor hollow with its convincing features, such as the flexible ladder-

type frame for great rigidity on the road and enormous torsional flexibility off the road, its superior four-wheel drive with differential locks in both axles and its portal axles for especially high ground clearance.

Do you have any questions, comments or suggestions on the topic of Unimog? Or want to know what the Unimog can do for you? Then don't hesitate to contact us. We are looking forward to hearing from you!

www.mercedes-benz.com/unimog





I would like to know more

Yes, please send me more information about the Unimog U20.

I am interested in the Unimog ... (required)

privately commercially

Does your company already use Unimog vehicles?

Yes No

Do you sometimes work in difficult terrain?

Yes No

Do you use various mounted bodies/implements?

Yes No

I want to be the first to find out the latest. Please send me the Unimog eNewsletter on a regular basis.

Your e-mail address

Company

Last Name

First Name

Position

Address

Postcode, Town

Country

Telephone

Area of business

Legal Notice: Your personal data will be stored to keep you regularly informed. Your data can be deleted, upon request, at any time. You can cancel the use of your personal data by contacting us in writing at: Daimler AG Special Trucks Division, HPC 185, Stichwort Datenschutz, 76742 Worth, Germany.

NE PAS AFFRANCHIR

DO NOT AFFIX STAMP

REPONSE PAYEE/REPLY PAID
ALLEMAGNE

Daimler AG
Produktbereich Sonderfahrzeuge
Postfach 21 03 30
76153 KARLSRUHE
ALLEMAGNE

A Daimler Brand



www.mercedes-benz.com/unimog

Mercedes-Benz

Concerning the Details in this Brochure: the products may have undergone slight changes after the editorial deadline of this brochure. We, the manufacturers, reserve the right to make any constructional changes, design alterations, colour modifications as well as changes to the scope of delivery during the delivery period, as long as the changes or modifications are not unreasonable for the customer. The salesman and/or manufacturer are not legally bound as long as they describe the order or the ordered articles with symbols or numbers. The pictures in this brochure may also contain accessories or special fittings that do not belong to the standard scope of delivery. Colour modifications are due to typographical causes. This printed matter may also contain models and customer services that are not available in individual countries. Statements concerning statutory, legal and tax regulations and the implications thereof are only valid for the Federal Republic of Germany prior to the deadline of this brochure. Please consult your Unimog Partner with respect to the latest binding regulations and stipulations and their implications. www.mercedes-benz.com/unimog