

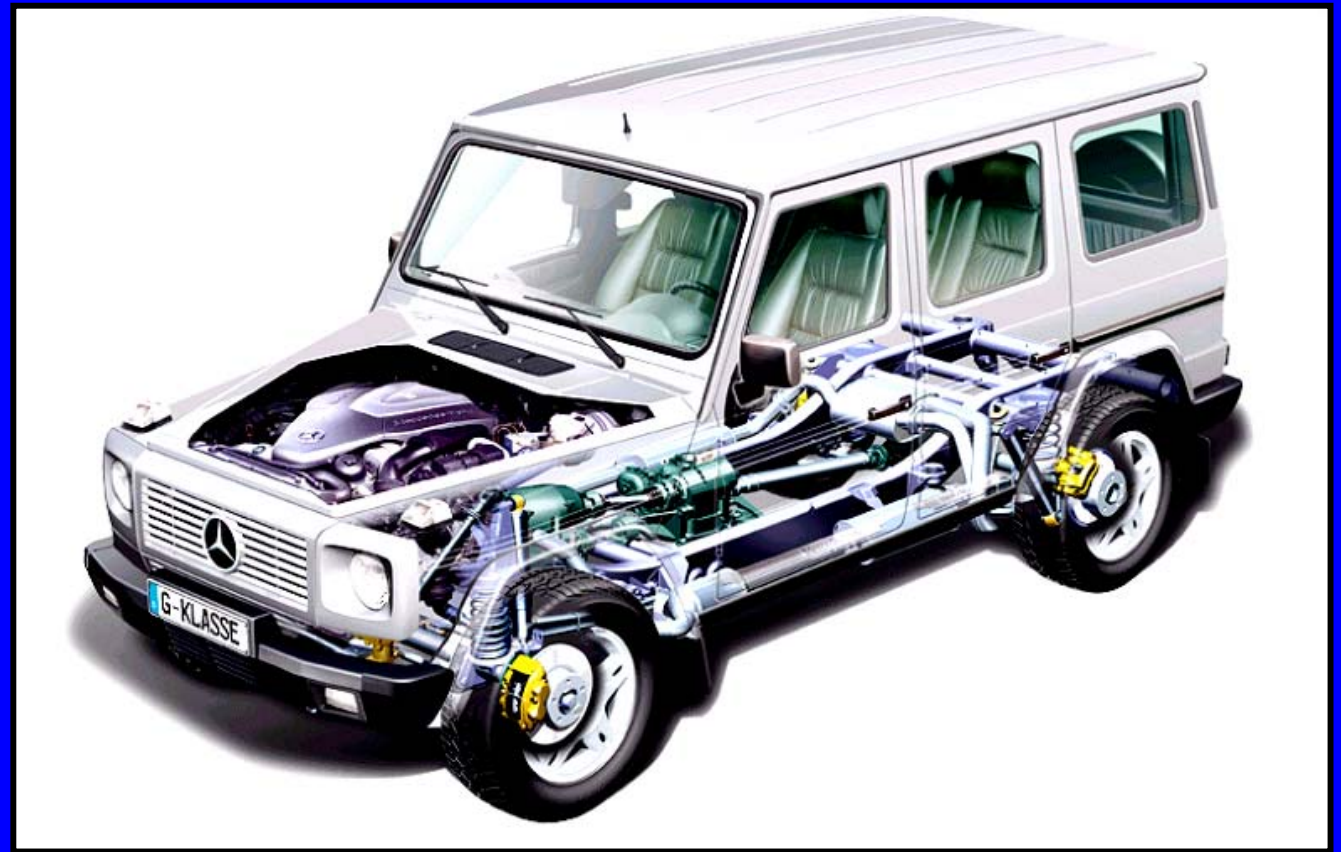

Mercedes-Benz

# G Class Transfer Case



These technical training materials are current as of the date noted on the materials, and may be revised or updated without notice. Always check for revised or updated information.

To help avoid personal injury to you or others, and to avoid damage to the vehicle on which you are working, you must always refer to the latest Mercedes-Benz Technical Publication and follow all pertinent instructions when testing, diagnosing or making repair. Illustrations and descriptions in this training reference are based on preliminary information and may not correspond to the final US version vehicles. Refer to the official introduction manual and WIS when available.

*Copyright Mercedes-Benz USA, LLC, 2003*

**MBMANUALS.COM**

*Reproduction by any means or by any information storage and retrieval system or translation in whole or part is not permitted without written authorization from Mercedes-Benz USA, LLC or its successors.*

*Published by Mercedes-Benz USA, LLC*

*Printed in U. S.A.*

# Transfer Case Identification

VG 150 E 3W / 2.14

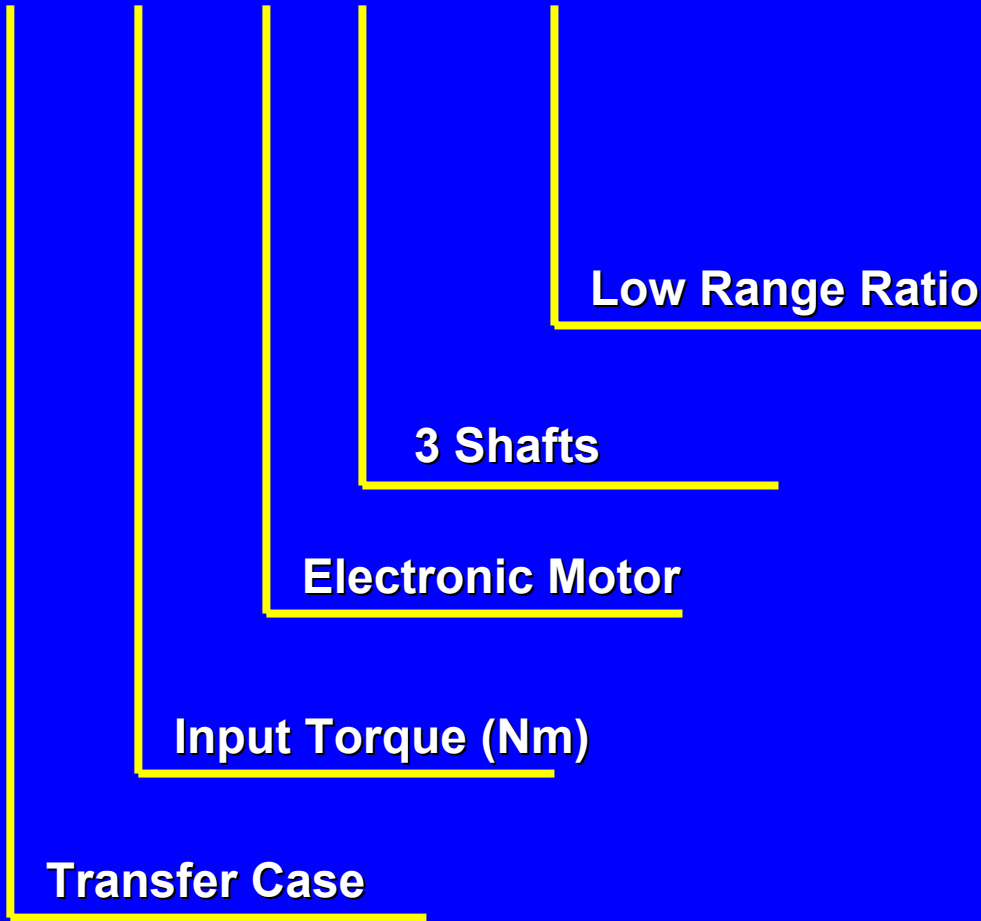

ID tag at rear of Transfer case

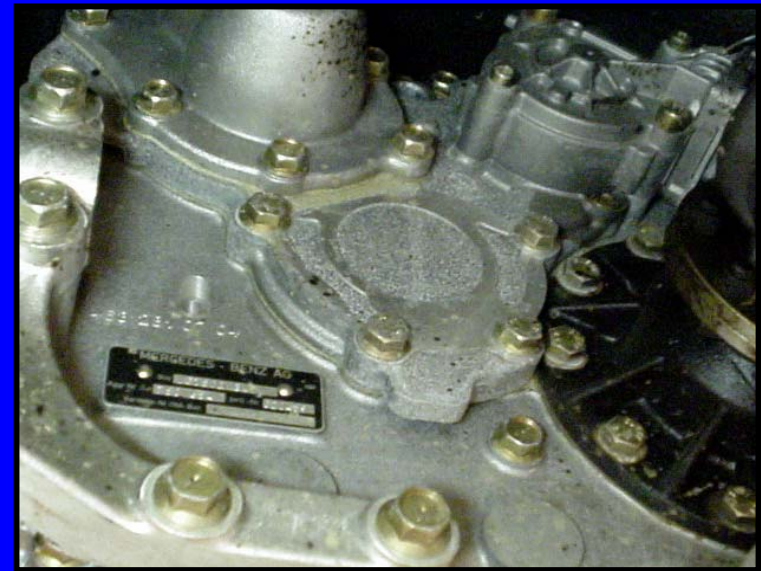

Only 1 version / ratio for USA application - High range 1.05

# Maintenance

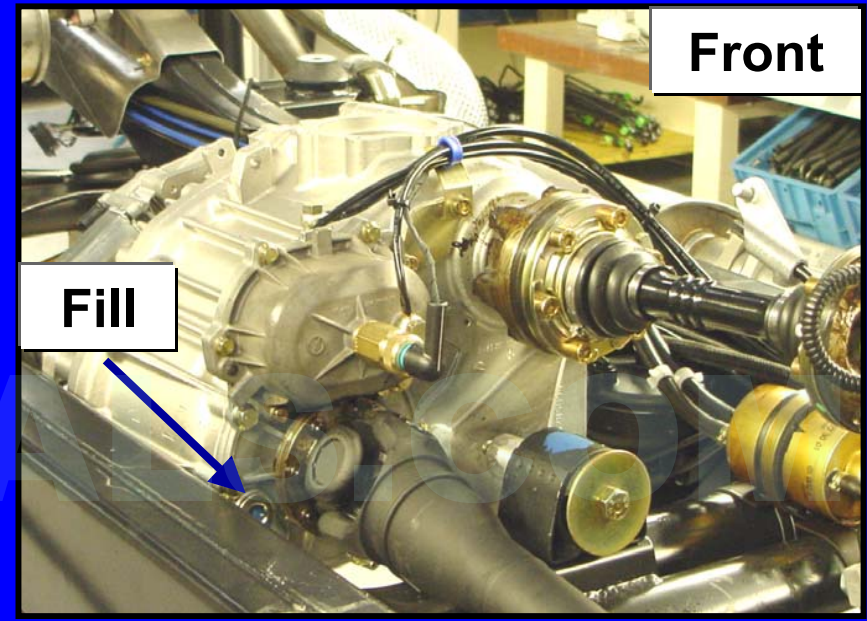
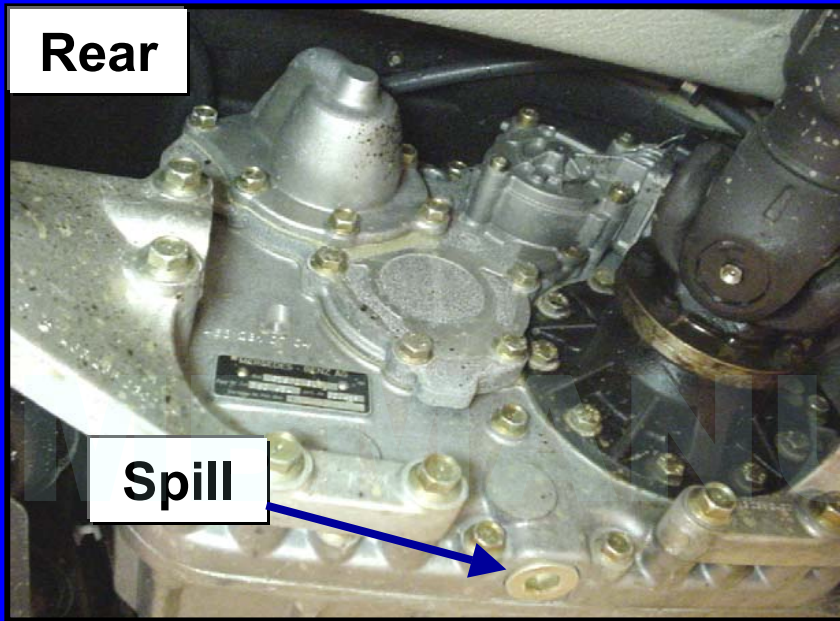

- Every B service check oil level (check cold)
- Oil change - 60,000 miles or 5 years since last change
- Oil grade - DEAGEAR Synthetic SAE 75W - 90  
(sheet # 231.1 car / off road vehicles)  
2.8 liters or 2.9 quarts

# Exploded View

1. Coupling flange
2. End cover
3. Shift fork
4. Shift cylinder housing
5. Diaphragm
6. Differential lock shift mechanism
7. Front transmission cover
8. Transmission housing
9. Intermediate flange
10. Rear axle input shaft cover
11. Intermediate flange cover
12. Input shaft
13. Countershaft
14. Differential

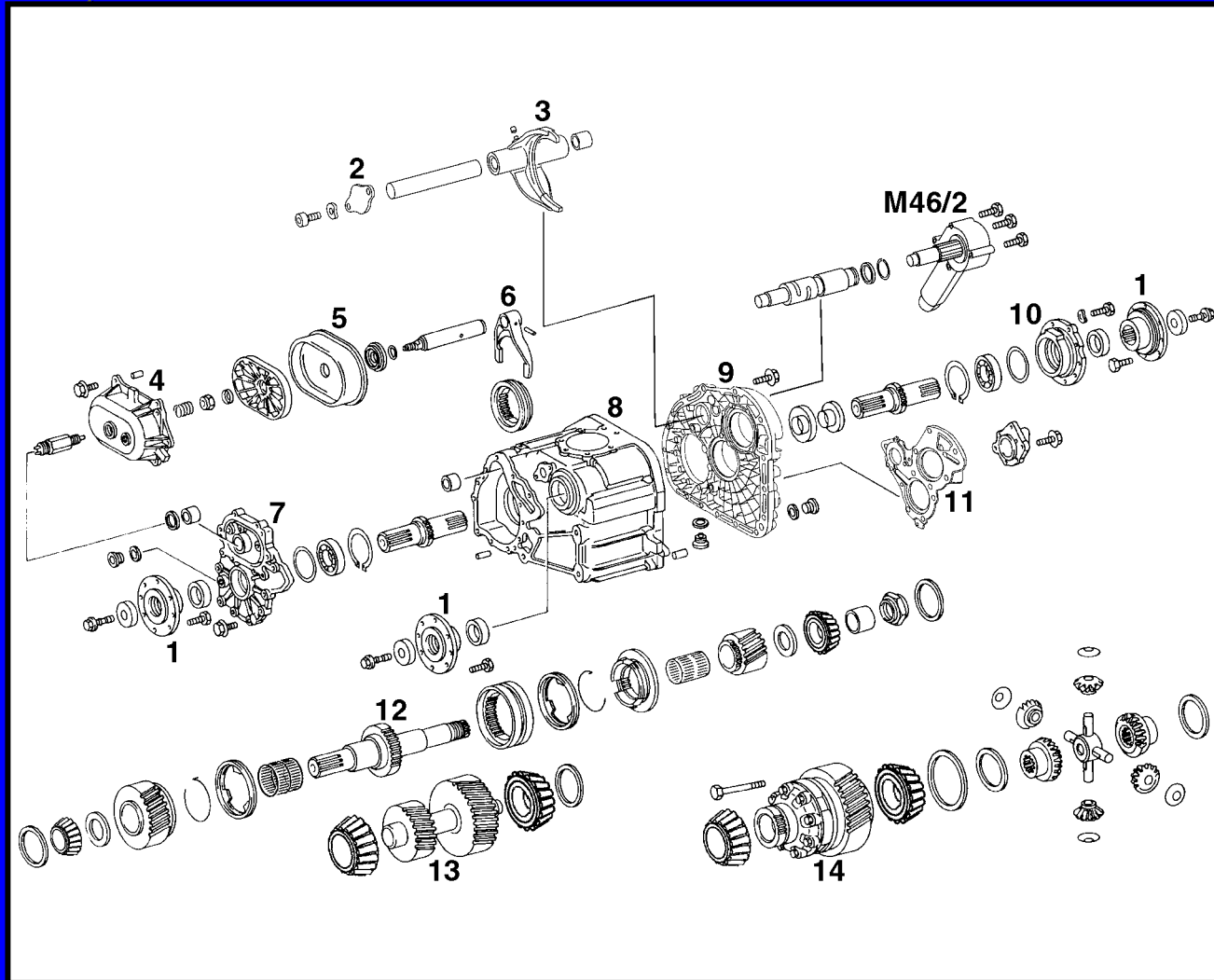

(M46/2) Transfer case  
actuator motor

# Coupling Flanges

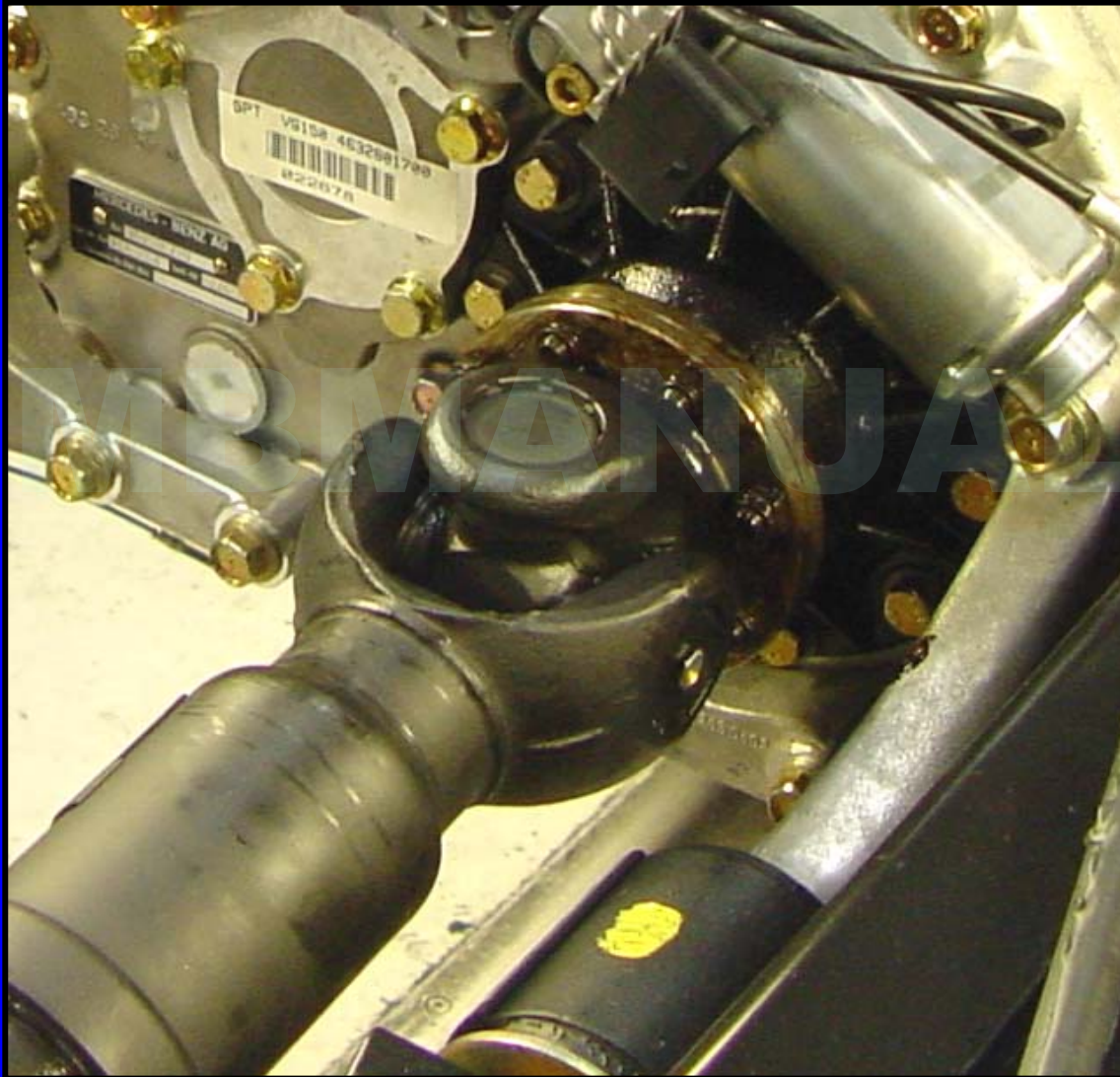

Flange position is vital:

- mark propeller shaft to flange
- mark flange to shaft

Tool for removing  
coupling flanges

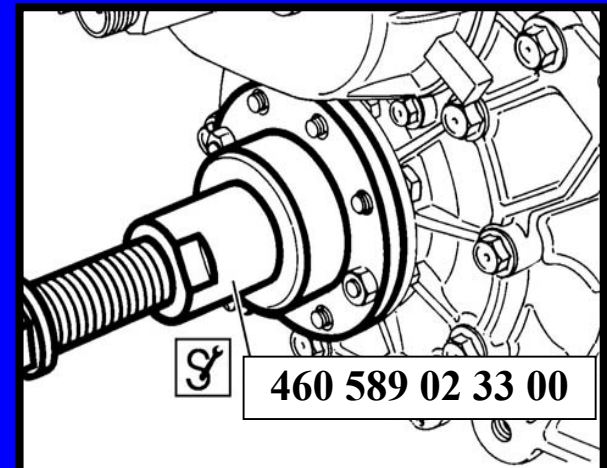

# Coupling Flanges

Check concentricity of flange

- vibration complaint
- replacement of coupling flange

Specification:  $\leq 0.07$  mm

If there are deviations perform adjustment:

- Offset flange 180° clockwise & recheck
- If not within specification offset flange 90° clockwise & recheck
- If not within specification offset flange 180° clockwise & recheck
- If the specified concentricity value is not achieved, replace flange & recheck

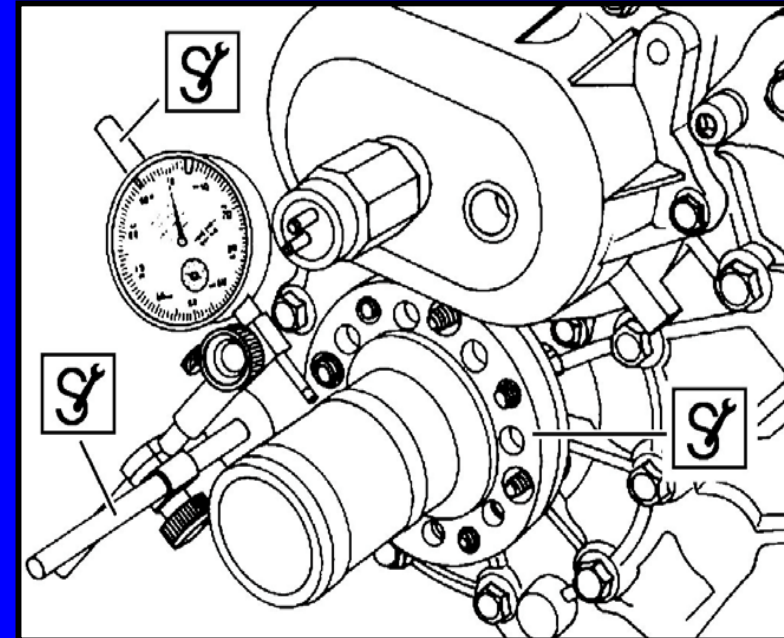

Measuring flange	460 589 01 23 00
Dial gauge	001 589 53 21 00
Dial gauge holder	363 589 02 21 00

# Radial Shaft Seals

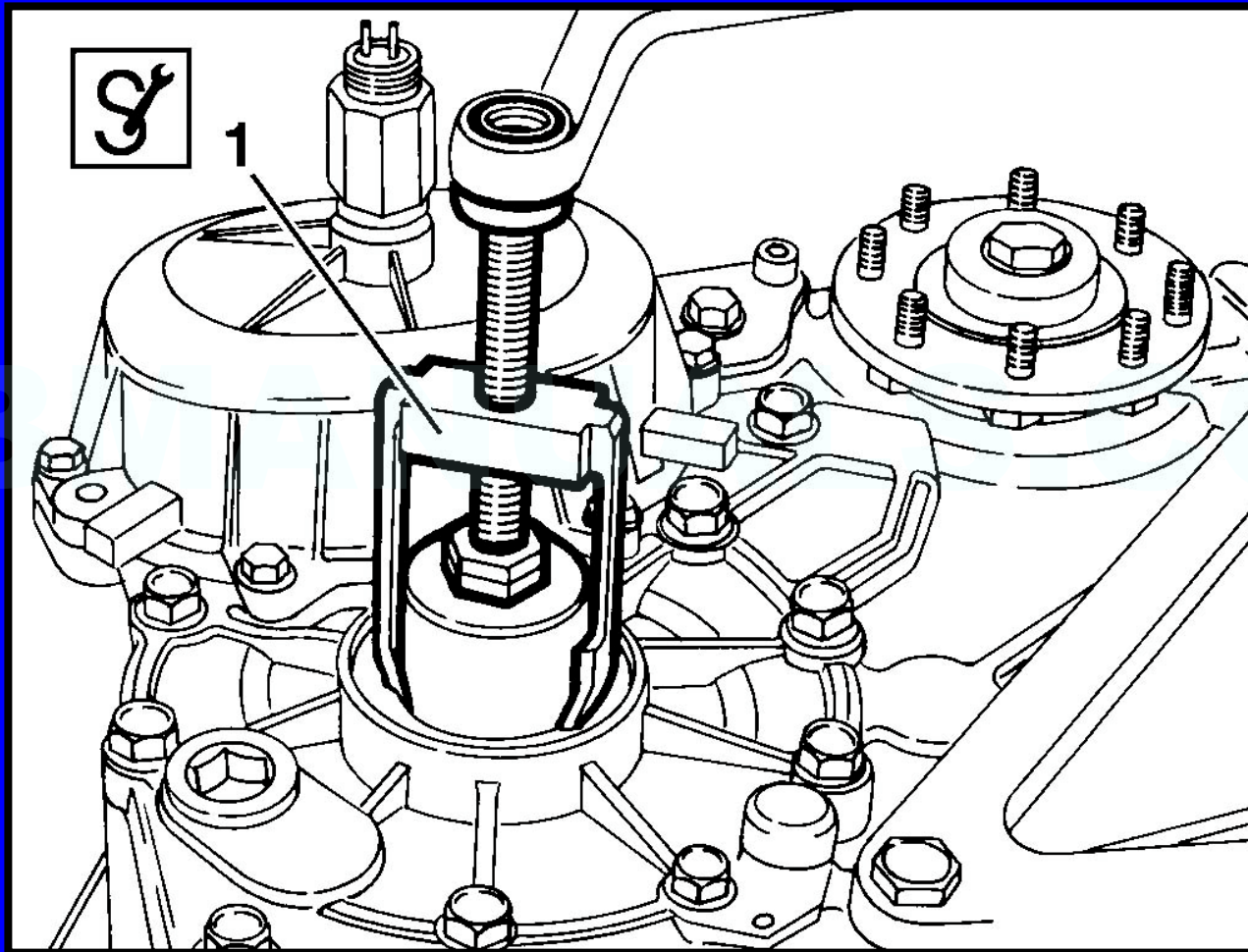

Puller part # 463 589 00 33 00 28 B



# Input Shaft

1. Washer
2. Tapered roller bearing
3. Washer
4. **High range gear**
5. Spring
6. Synchronizer cone
7. **Needle roller bearing**
8. **Input shaft**
9. **Sliding sleeve**
10. Synchronizer cone
11. Spring
12. Synchronizer ring
13. **Needle roller bearing**
14. **Low range gear**
15. Washer
16. Straight pin
17. Tapered roller bearing
18. Spacer nut
19. Nut
20. Washer

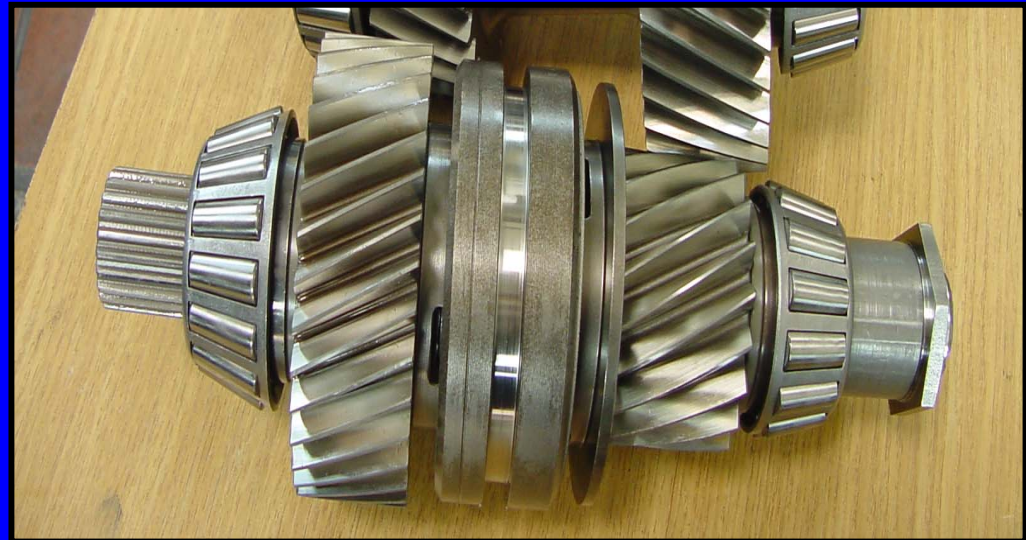
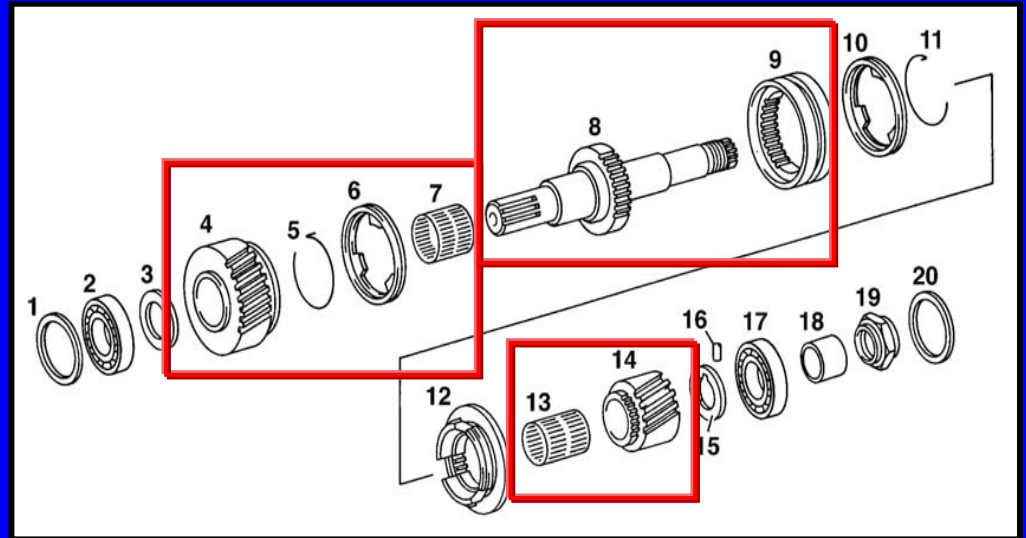

# Input Shaft

Input shaft serviceable

- use correct tools as described in WIS to disassemble / assemble shaft
- when installing new bearings heat bearings to 120°C Max.

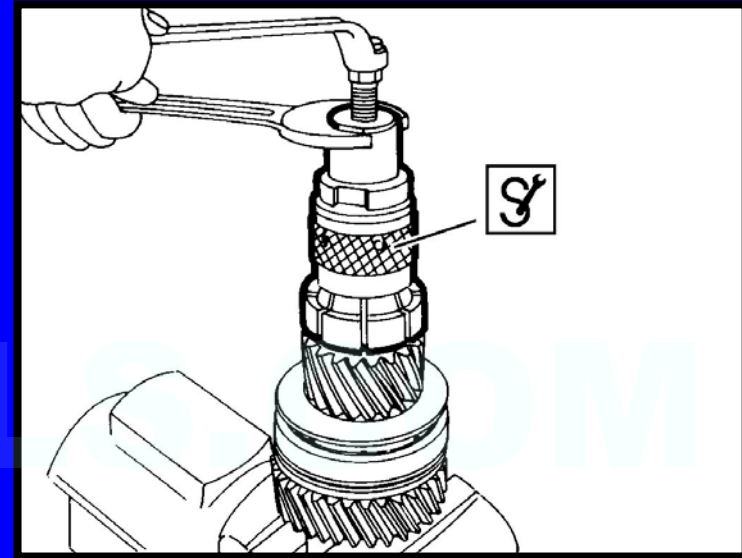

If parts are replaced  
adjust input shaft  
axial play

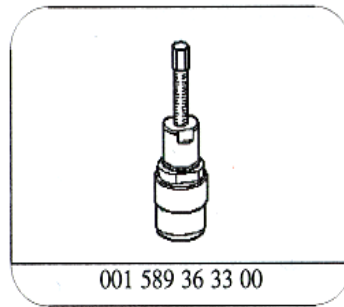

Puller

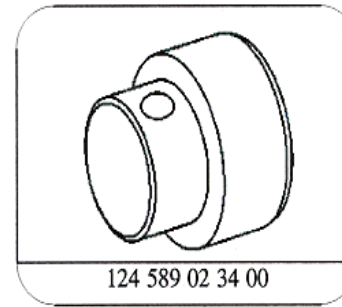

Thrust piece

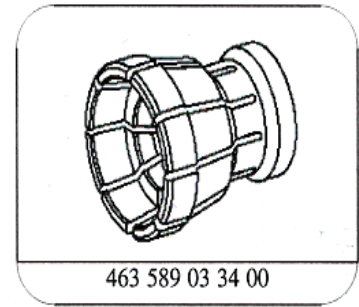

Clamping pliers

# High / Low Shift Fork

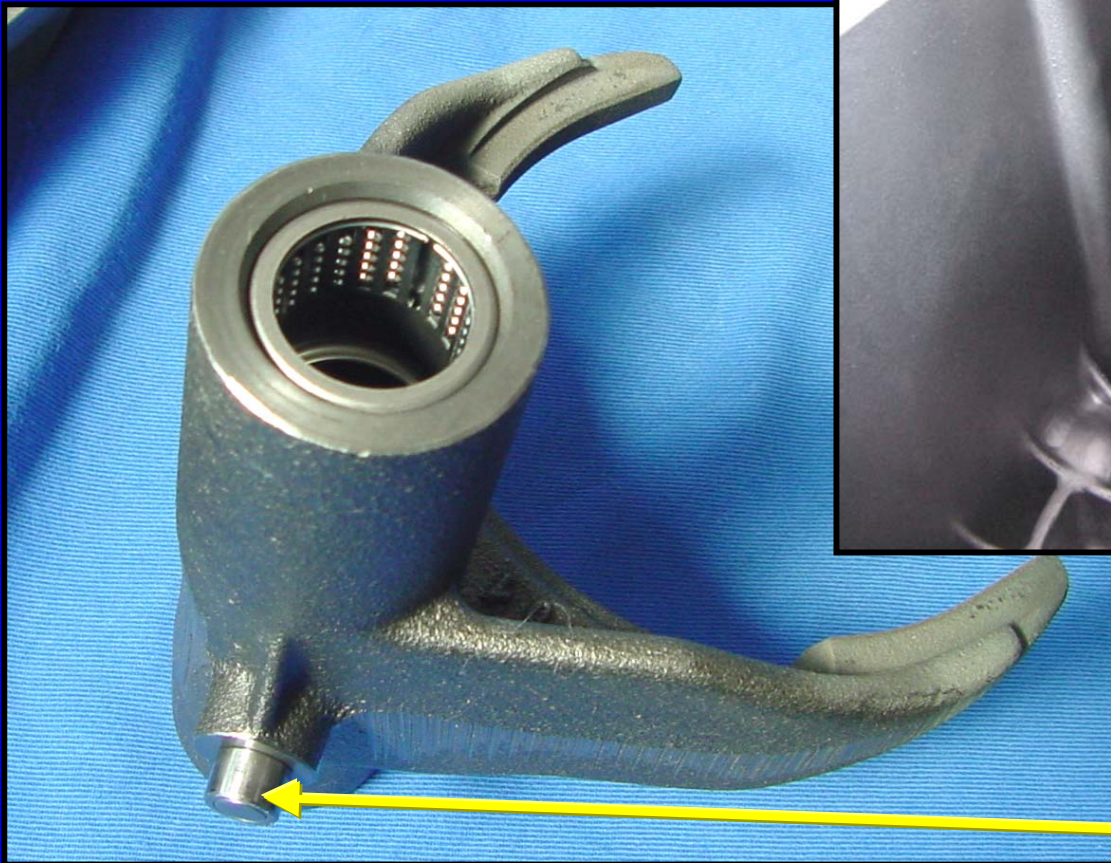

Removable barrel  
bushing

# High / Low Shift Fork

- 1) Motor (M46/2)
- 2) Worm gear
- 3) Actuating wheel
- 4) Barrel sleeve
- 5) Shift fork
- 6) Shifter shaft

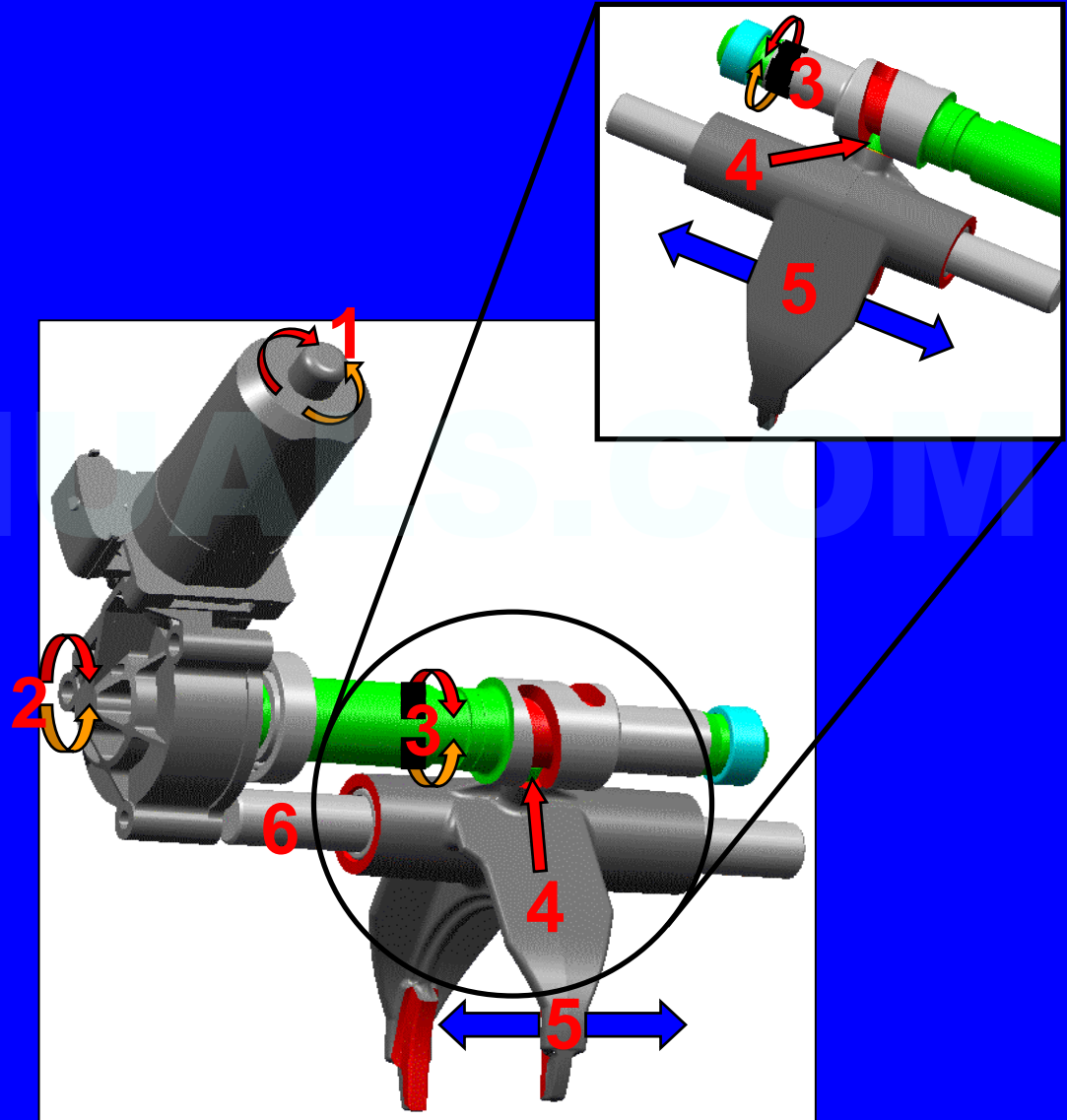

# Countershaft

- Countershaft gears not serviceable
  - if damaged, replace assembly
- Countershaft bearings serviceable
  - use correct tools as described in WIS to disassemble / assemble shaft
  - when installing new bearings heat bearings to 120°C Max.

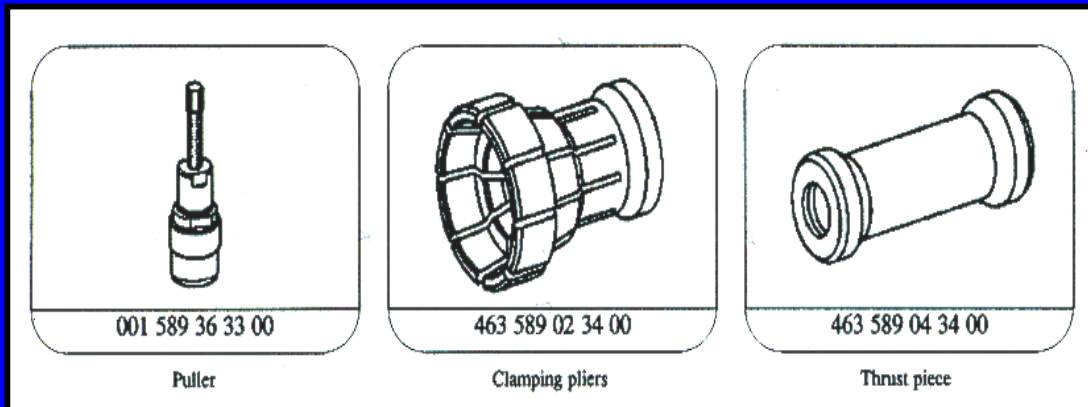

If parts are replaced adjust  
countershaft axial play

# Axial Play Adjustment

Procedure is the same for the input and countershaft. The following example shows input shaft axial play adjustment.

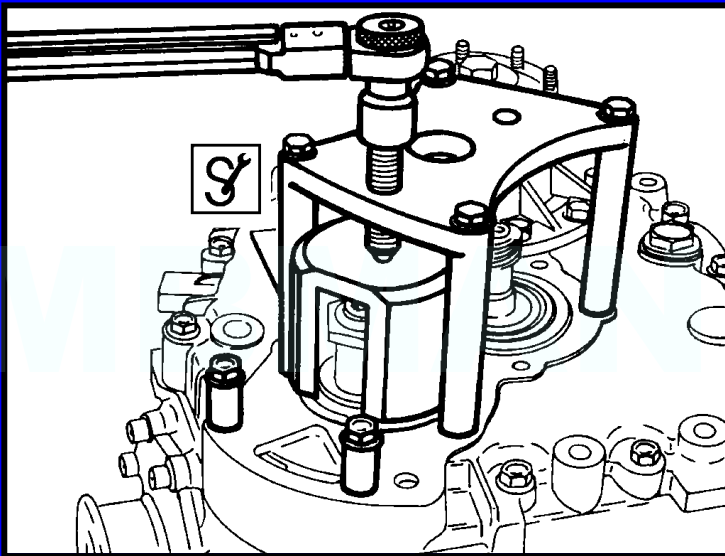

Thrust device #463 589 00 21 00

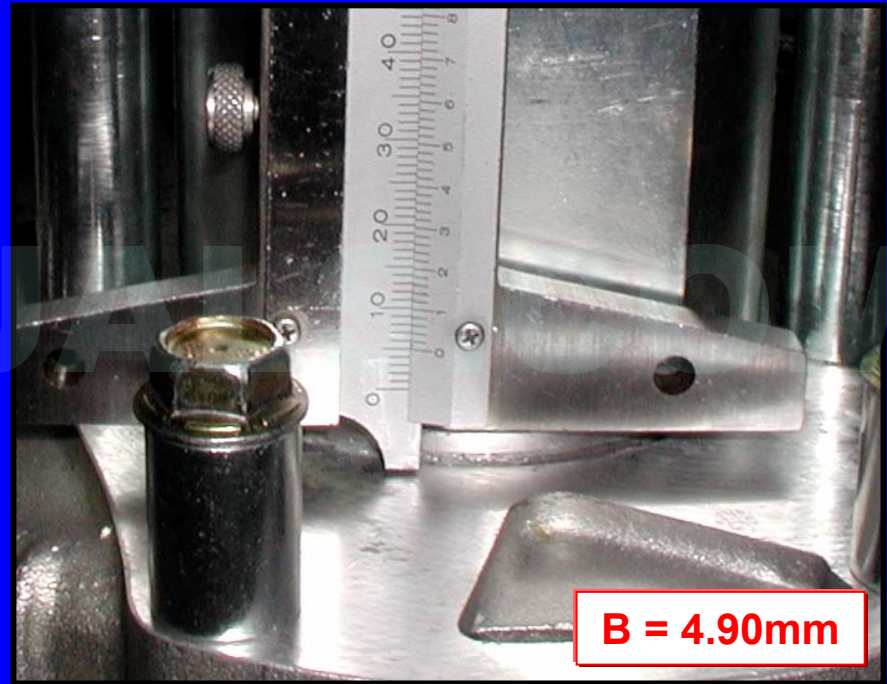

- 1) Install thrust device with spacers & tighten compressing bolt to 15Nm
- 2) Spin input shaft approx. 10 times to position the bearings
- 3) Measure distance between outer race and intermediate flange  
- B (example 4.90mm)

# Axial Play Adjustment

- 4) Measure depth between intermediate flange cover and bearing seat - A

## Calculation example:

Depth A 5.50 mm

Distance B - 4.90 mm

---

**Difference** = 0.60 mm

*Preload on bearings* + 0.10 mm

---

**Shims required** = 0.70 mm

Spec is 0 mm play + preload of (0.1 mm  $\pm$  0.05)

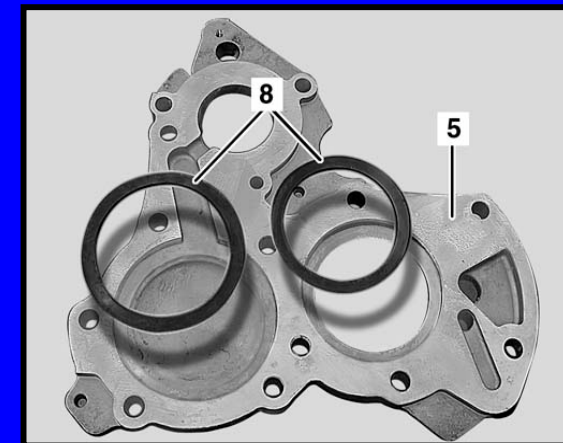
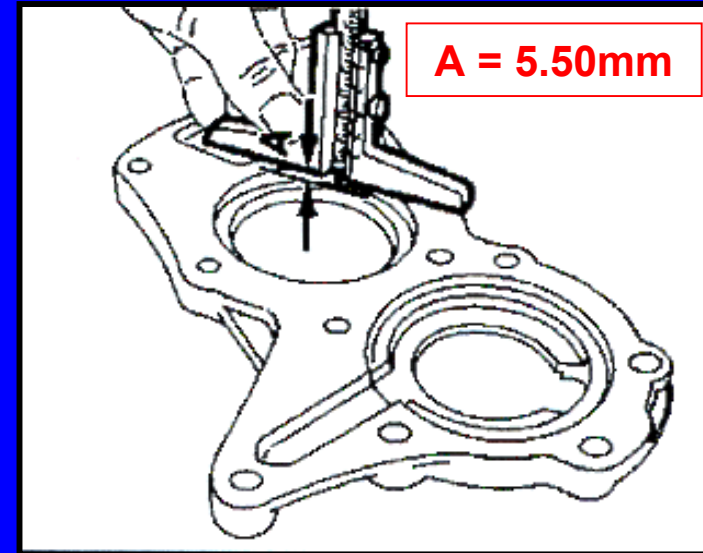

- 5) Install the appropriate shims:  
available thickness  $\rightarrow$  0.1, 0.15, 0.3 & 1.0 mm

# Center Differential

1. Front tapered roller bearing  
*(shown with inner & outer race)*
2. Differential housing
3. Rear tapered roller bearing  
*(shown with inner & outer race)*
4. Shim
5. Thrust washer
6. Shaft bevel gears
7. Differential spider gears
8. Differential bevel gears
9. Spherical washers

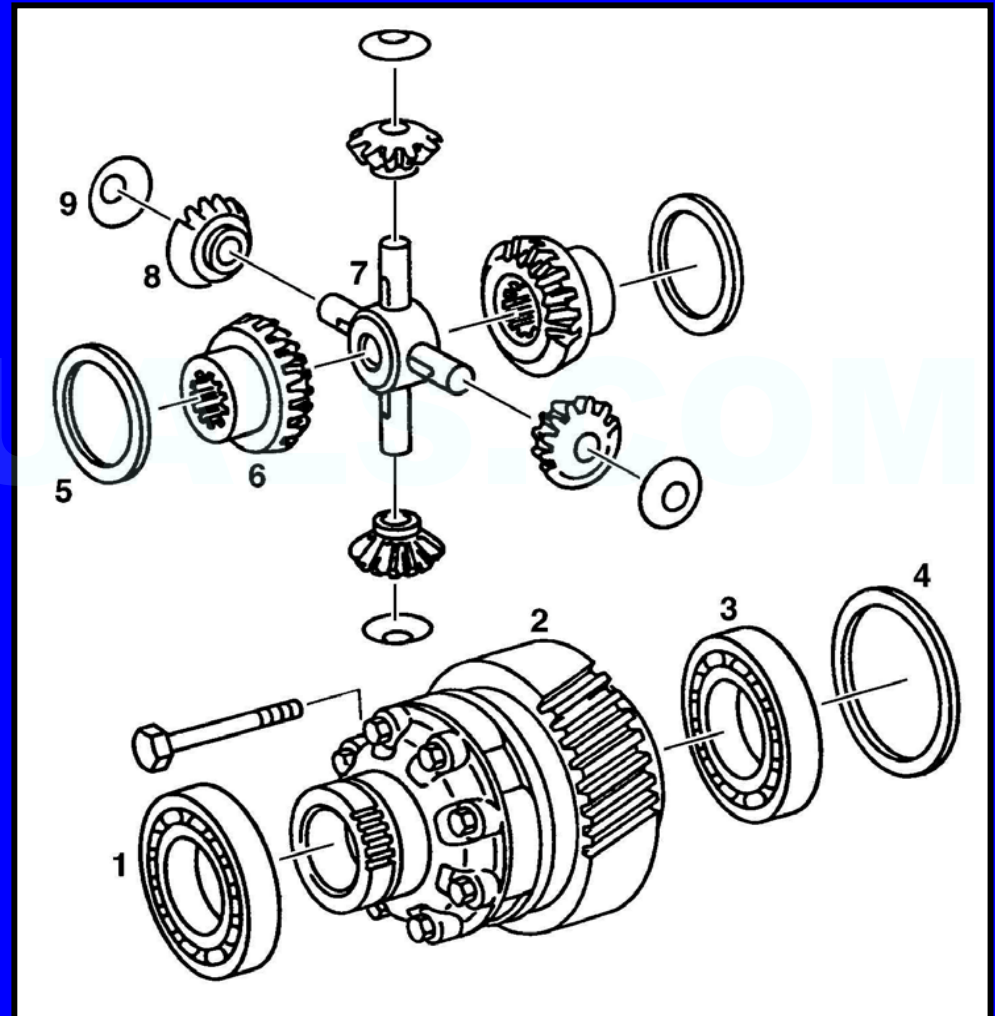



# Center Differential

- Center differential serviceable
  - use correct tools as described in WIS to disassemble / assemble
  - when installing new bearings heat bearings to 120°C Max.
- If replace differential bevel gears
  - check friction torque of differential AR28.50-P-1023-05B
- If other parts are replaced
  - adjust center differential axial play AR28.50-P-1023-04B



# Center Differential Axial Play

- Remove outer race (2) and shims (3) from axle input shaft bearing cap (4)
- Install new outer race with a 1.0 mm shim
- Install axle input shaft cover (4) with 3 equally spaced bolts (5 Nm)
- Measure gap at bearing cap with feeler gauge - (e.g. 0.80 mm)
- Calculate correct shim required: Specification = 0.1 mm (+/- 0.05 mm)

0.80 mm - 0.10 = 0.70 mm shim (shims available 0.1, 0.15, 0.3 & 1.0 mm)

- Remove outer race and reinstall with appropriate shims

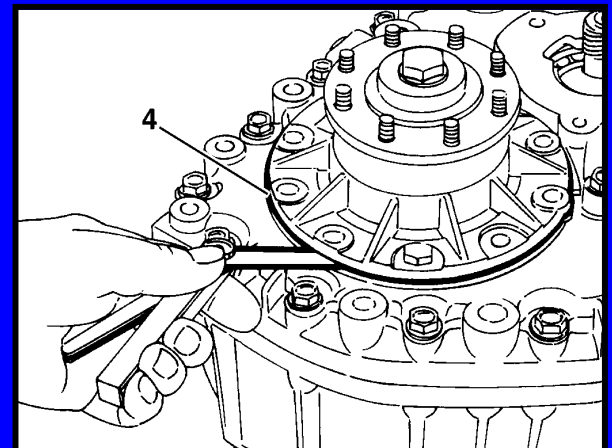
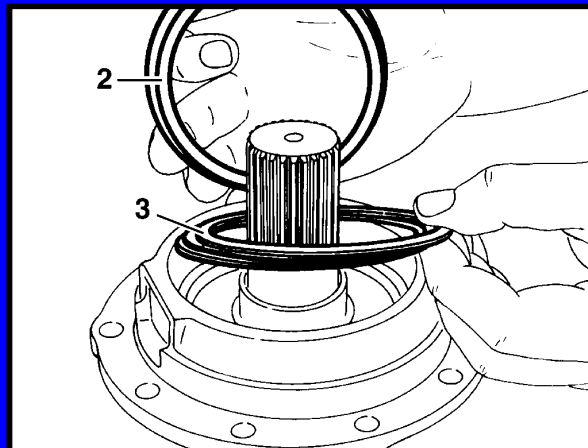
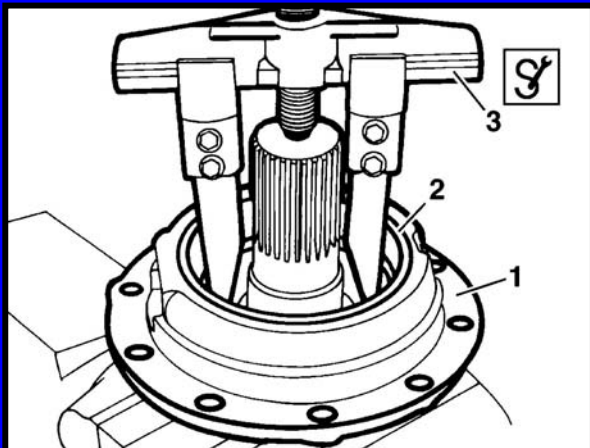

# Bearing Cap

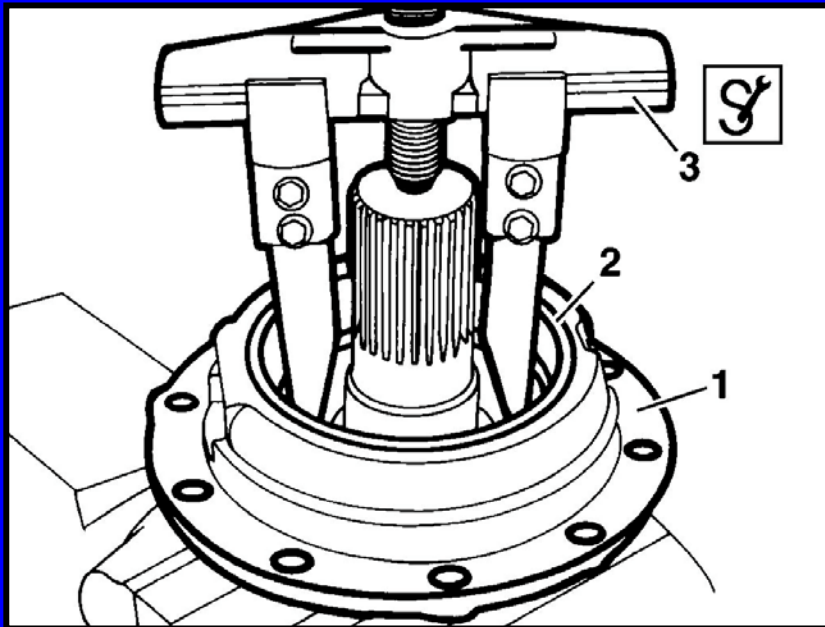

Puller 000 589 88 33 00 28 B

- Used with puller arms
- 463 589 05 34 00 (26C)
- Thrust piece 463 589 01 34 00 (28B)

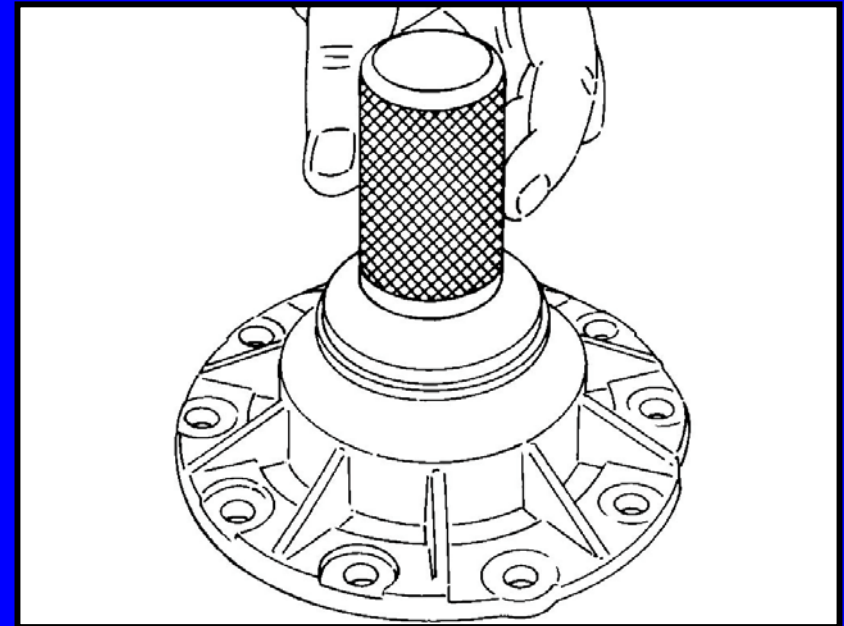

Drift punch 463 589 00 15 00 28 B

# Transfer Case Power Flow

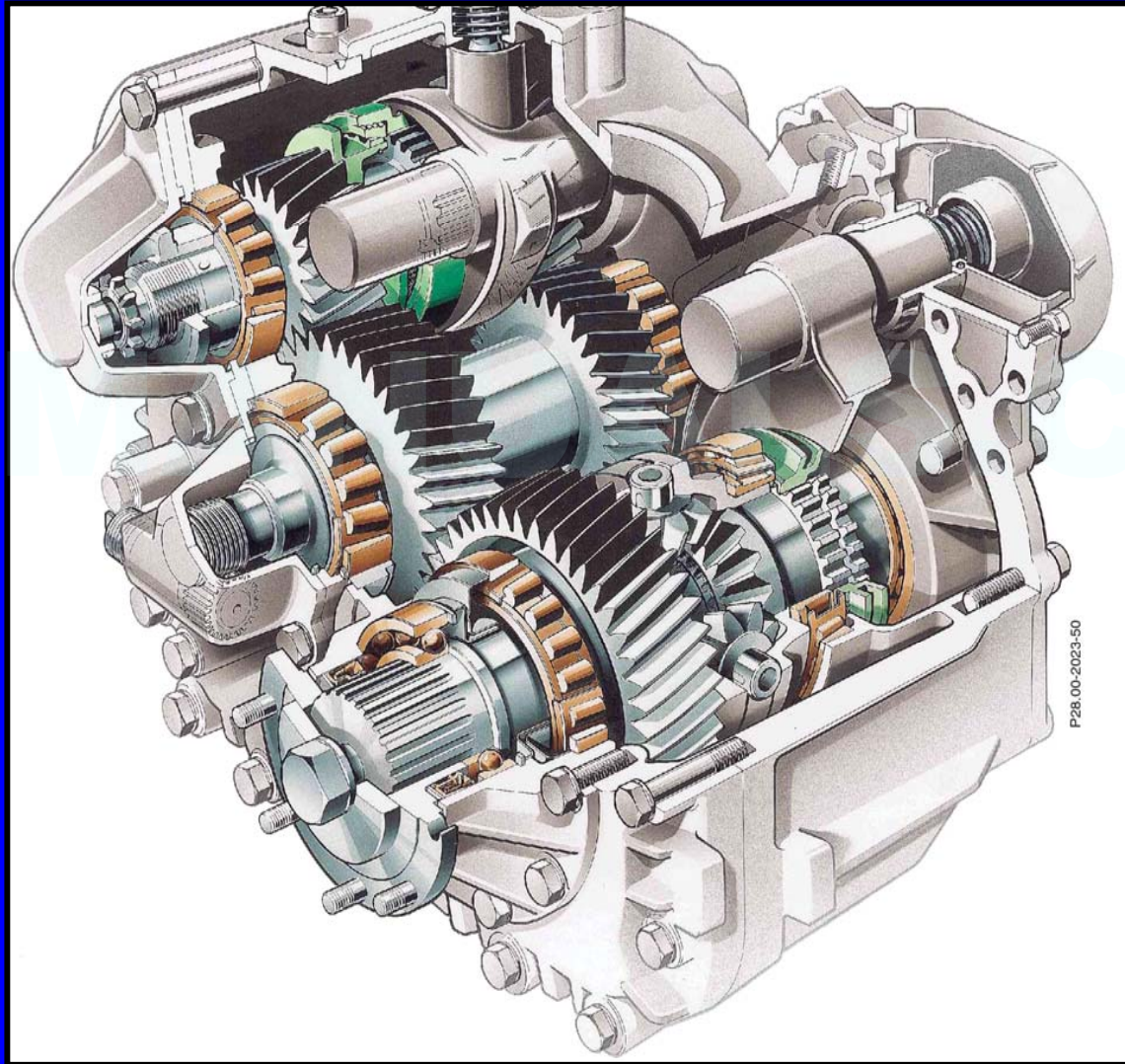

MB

OM

# Power Flow

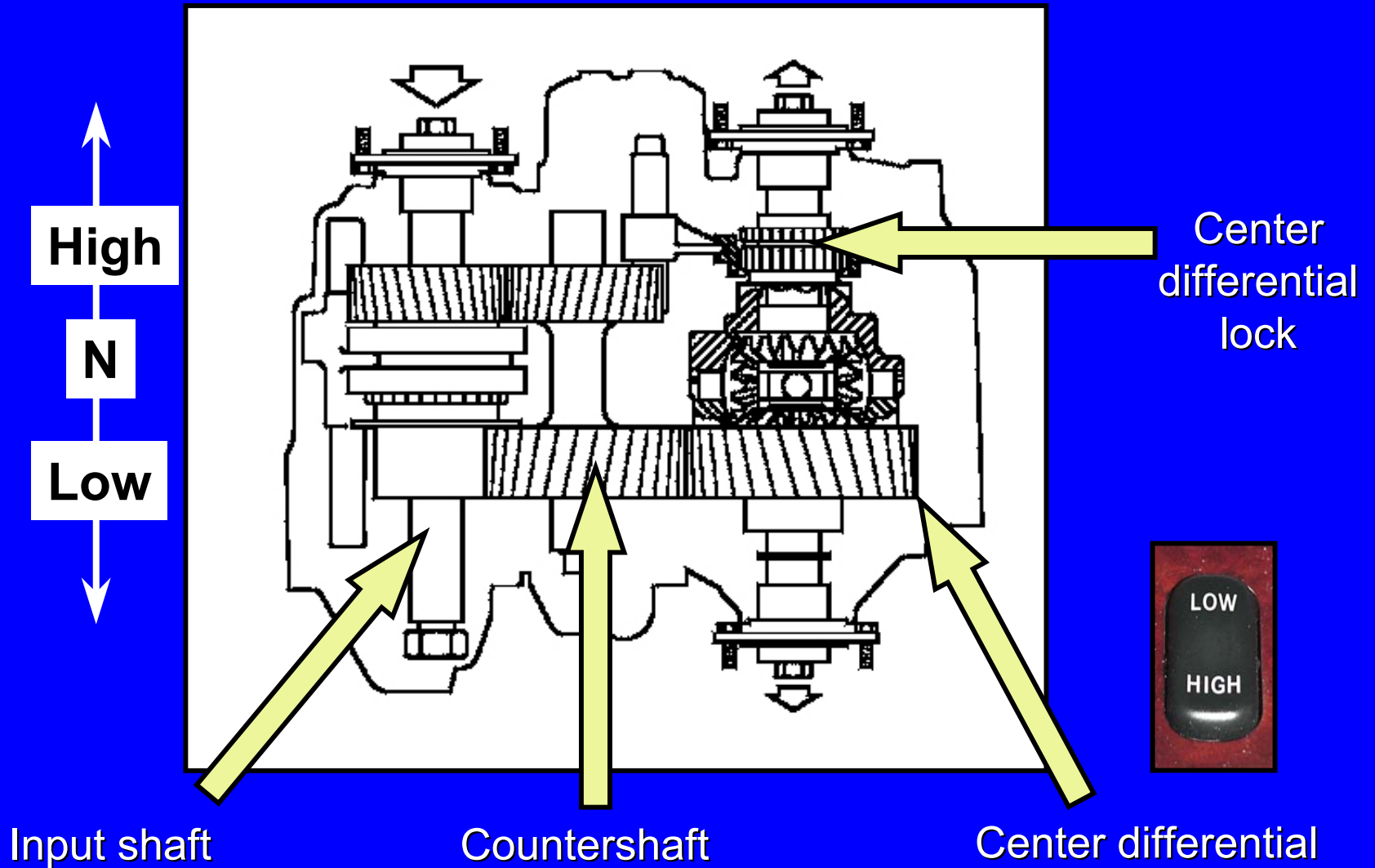

# High Range

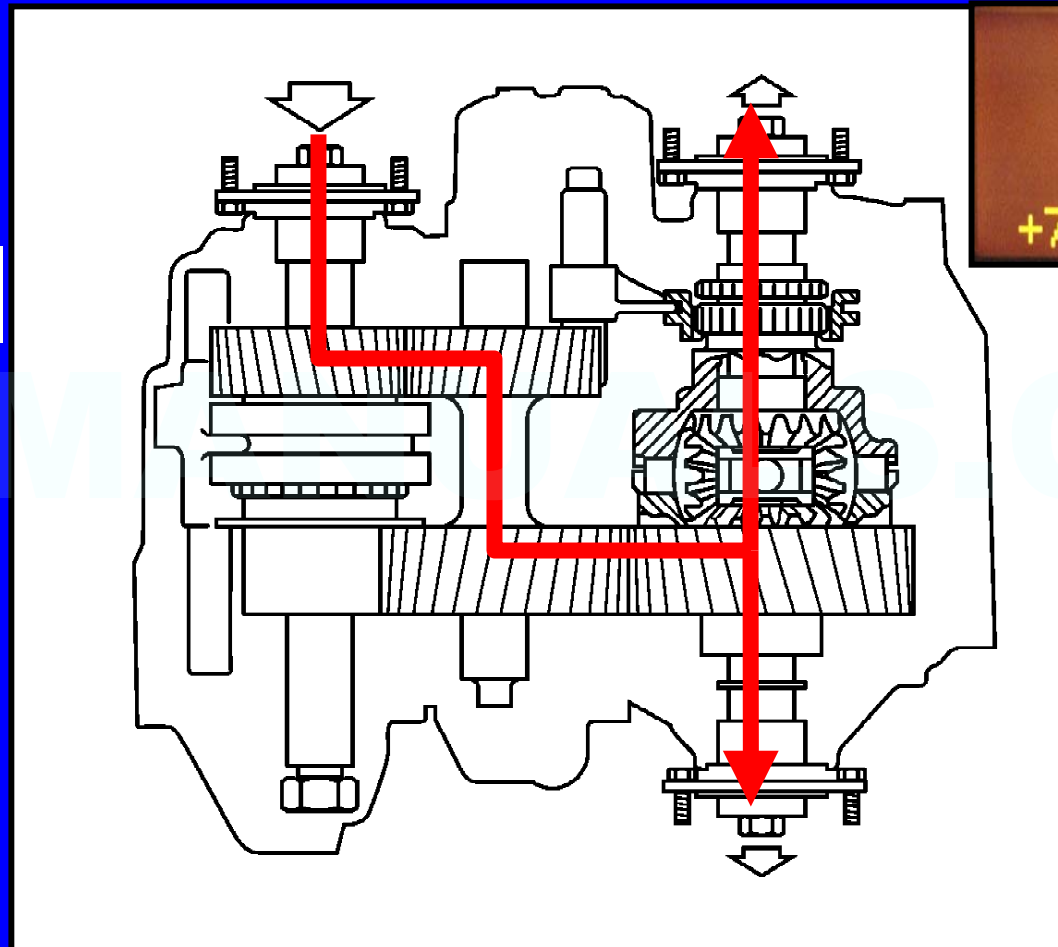
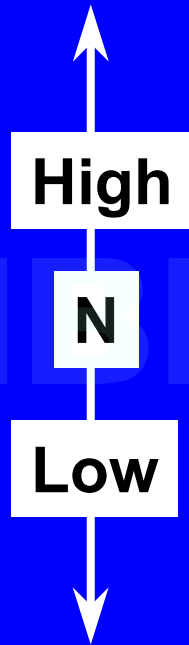

1.05:1

# Low Range

↑  
High  
N  
Low  
↓

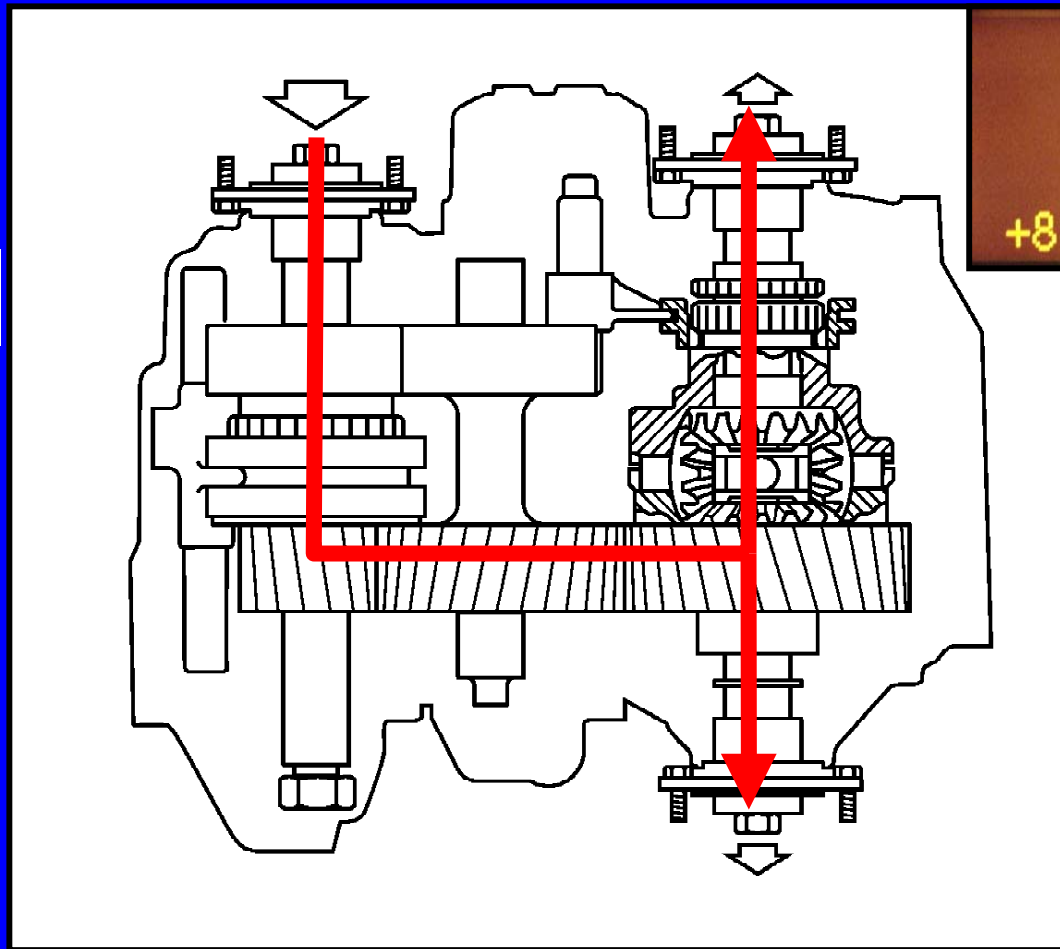

2.15:1

# Low Range (Diff Locked)

High  
N  
Low

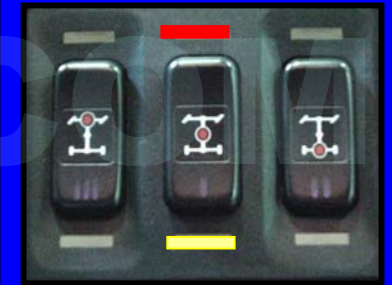
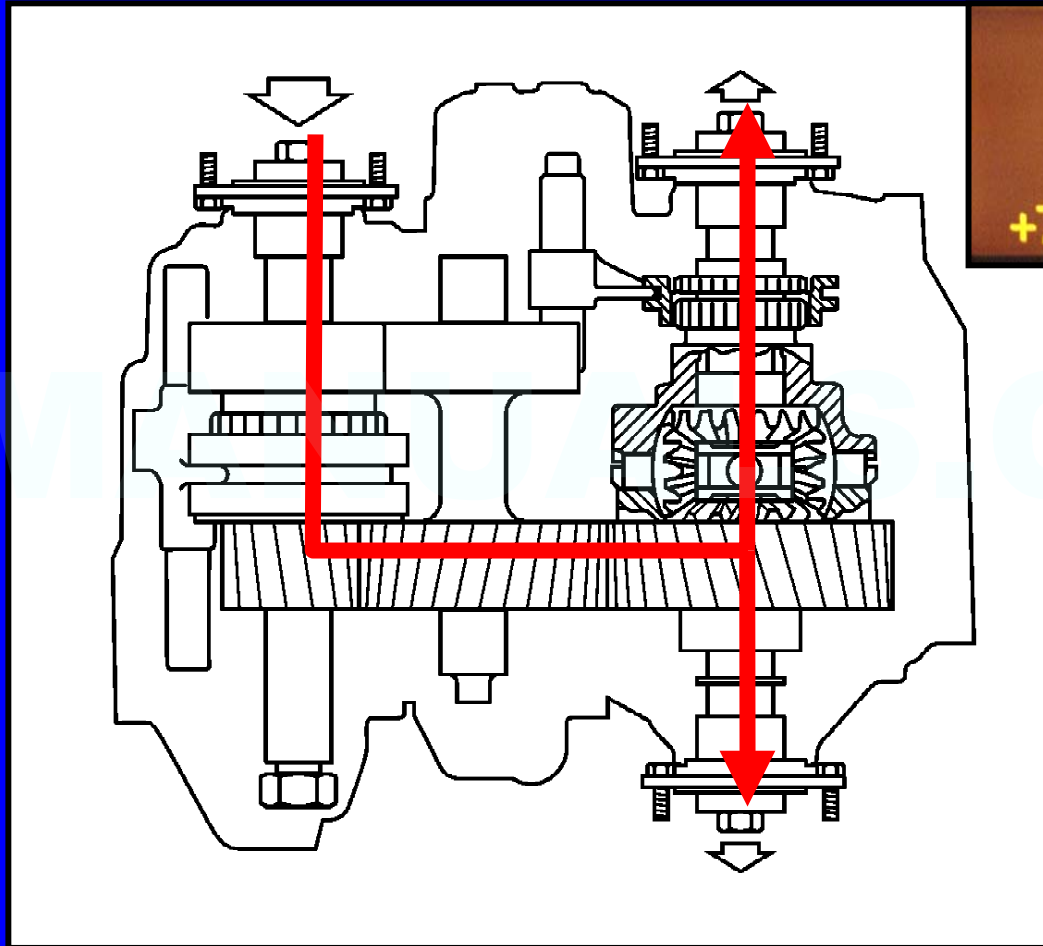



# Neutral

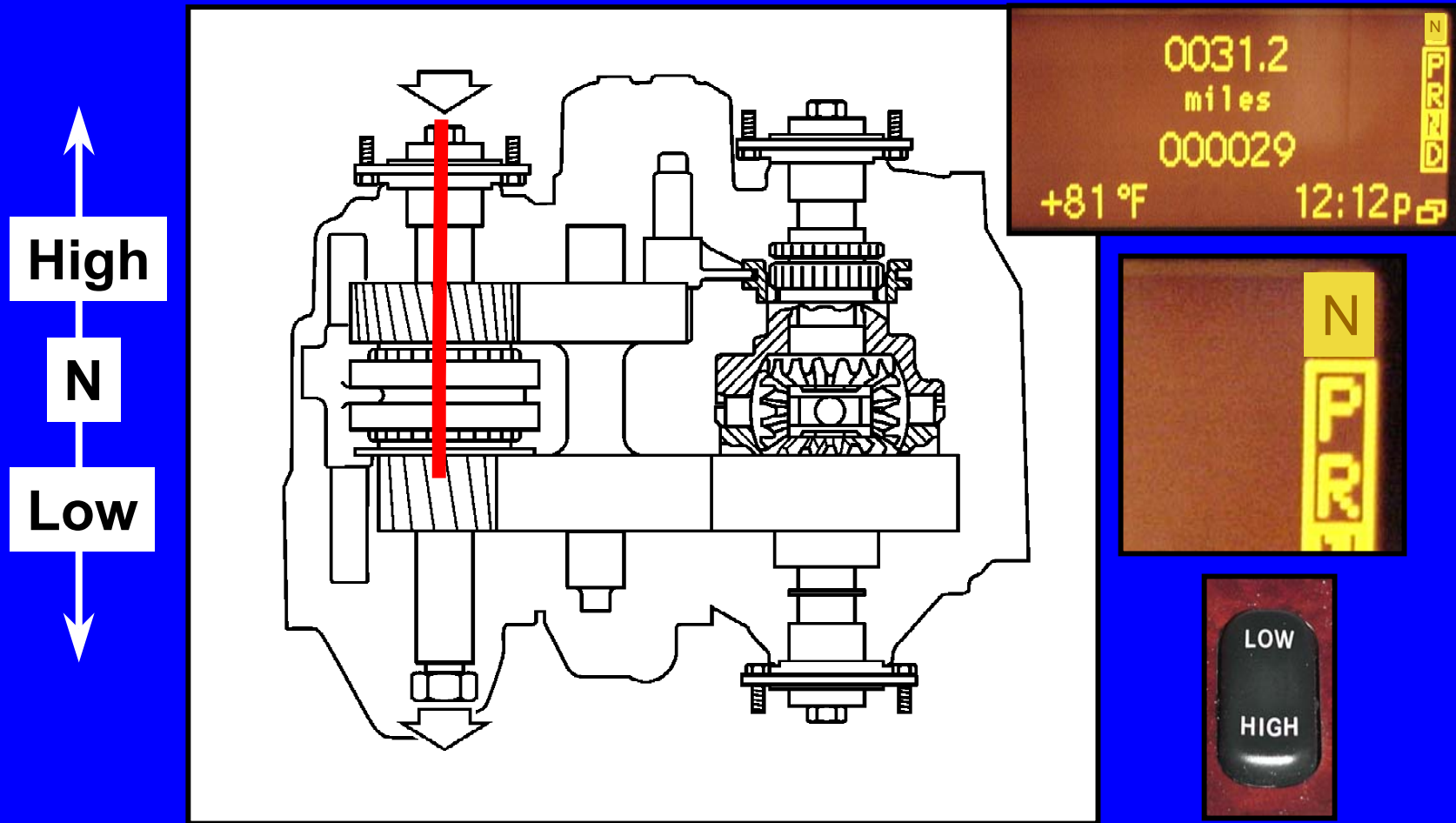

Input shaft bearings can be damaged if engine runs for extended period of time with transmission not in park. (no oil reaches bearings)